

**IMPORTANT:**

Therapeutic Equipment should be evaluated and recommended by a licensed therapist. Information contained in this document should be considered for reference use only.

 **TRIVEL**

User Manual  
V.1

T350 / T250

## Contents

Welcome word .....	2	Opening the stem clamp .....	14
About us .....	2	Positioning the handlebar .....	14
A Word on safety .....	2	Transferring a user .....	15
Riding safely.....	5	Engaging the parking brake .....	15
Before your first ride .....	6	Adjusting the seat height .....	15
Before each ride .....	6	Releasing the handlebar.....	16
Adjusting the seat.....	7	Fitting and adjusting the lateral supports .....	16
Recommended rider position.....	7	Adjusting the guide bars.....	17
Seat height adjustment .....	8	Fitting the abductor pommel .....	18
Seat reach adjustment .....	9	Fixed / Freewheel drive modes.....	19
Back support angle adjustment.....	9	Fixed drive mode.....	20
Adjusting the pedal heel support .....	10	Freewheel drive mode .....	21
Adjusting the pedals distance.....	11	Advanced adjustments.....	22
Adjusting the stem .....	12	Brake cable tension adjustment.....	22
Stem height adjustment .....	12	Rear steer cable tension adjustment .....	22
Stem angle adjustment.....	13	Stem clamp adjustment .....	23
Positioning the front handlebar .....	14	Warranty terms and limitations .....	23

## Welcome word

Congratulations on your purchase! We are confident that you will enjoy riding your new Trivel tricycle as we spent a great deal of time designing it with you in mind!

This manual will get you through the necessary information about safety, usage, and maintenance of your new tricycle so you can experience the most of it, for many years.

Please read this manual thoroughly before the first ride and keep in handy for future reference.

If some instructions remain unclear to you, please do not hesitate to contact us or your dealer for further explanation.

## About us

For over 25 years, the passionate, dedicated Trivel team has been designing and manufacturing tricycles for reduced mobility children and adults, thus providing them with hours of fun and

pleasure. We can install a wide range of custom components onto your tricycle, so it is fully adapted to the user's specific needs.

To learn more about our products, parts, accessories and services, please visit [www.trivel.com](http://www.trivel.com)

## A Word on safety

Trivel puts a great effort in developing the safest product possible. Riding a tricycle, like most other sporting activities, involves some risks. People who engage in this activity must be aware of those risks and fully assume them.

A Trivel is a very safe and stable vehicle thanks to its three-wheel triangular platform design. Although it is propelled in a similar way than a regular two-wheel bicycle, its handling characteristics are significantly different. Make sure to read and understand the [Riding Basics](#) section of this manual to learn about important advices on how to operate such a vehicle before your first ride.

Most of the accidents are caused by human factors such as bad judgment of a hazardous situation, improper handling or neglecting the equipment's mechanical maintenance.

Many serious injuries can be prevented only by wearing adequate protective equipment such as a homologated helmet.

Respecting the local road laws and getting to know how to properly use and maintain your tricycle with the help of this manual will also help significantly to reduce the risks of injuries.

It is the rider's responsibility to fully understand the usage of the equipment he or she is operating.

In the case of a child operating the tricycle, it is the responsible adult's duty to educate on local public road laws, supervise safe riding activity and ensure the proper fit, adjustment and good mechanical condition of the equipment.

The following signs will be used throughout the manual. They represent Warnings and Cautions about important or hazardous situations that must be fully understood to avoid damage to your equipment, personal injuries or even death.



*This sign indicates cautions about the proper use of the equipment or other important information.*



*This sign indicates a serious warning about a potential risk of injury or death or other safety information*

*Check all component connections and accessories attachment before every ride. Do not ride your tricycle with loose components or accessories. Take the tricycle to your dealer if necessary.*



*The user should wear a homologated helmet, it could save his or her life. Make sure it is properly attached and positioned on his or her head.*

*Always place user's feet safely on pedals. Use adequate pedal attachment system if needed.*

*If using a backrest, harness or any other support system, make sure to properly tighten the belts and straps on user.*

*Make sure the user's toes are not allowed to touch the ground at any time.*

*If you use the product outside, especially on public roads or sidewalk, wear bright, visible clothes. Preferably closely fitted to your body to avoid entanglement into components. Lace your shoes and the user's shoes properly.*

*Trivel is not responsible for accidents caused by the use or handling when tricycle is towed by an adult's regular bike, or by its capsizing when the child gets off his or her tricycle or when he or she activates the brakes.*

*When riding on public roads, always ensure you are visible to other road users. Make sure your tricycle has all the reflectors or lights that are required by the local laws. A safety pennant flag is also recommended for extra visibility.*

*Never ride under the influence of alcohol or illicit substances. This could seriously impair your judgment, reflexes or balance and may lead to prosecutions, serious injuries or even death.*

*Never carry a second passenger on your tricycle unless that is with an approved accessory equipment.*

*Do not carry anything on the handlebars or between your legs as this could seriously impact your balance or get caught in the wheels and may cause serious injury or death. Use the provided cargo compartment is your tricycle is equipped with such.*

*Make sure your tricycle is properly fitted to you and that you are fully able to control it.*

*Adapt your riding style and behaviour to each type of terrain, situation, and weather condition.*

*This product and its components were not designed to be used for extreme conditions or stunts. Do not engage in aggressive riding or jumps.*

*Do not use for downhill.*

*Trivel is not responsible for accidents caused using towing equipment.*

*Avoid using on wet or icy ground if possible. Wet and icy ground seriously reduces traction between tires and road surface. If you must, take extra caution as the risk of slipping and falling is much higher especially when turning and braking.*

*Avoid using at night if possible. Your vision is seriously reduced in the dark and you may not see obstacles coming at you in time to avoid them. Other road vehicles might also not be able to see you, and this can cause very dangerous situations potentially leading to serious injuries or even death.*

*When riding with children, always keep a close eye on them and try to stay away from potential hazardous situations such as stairs, steep descents, curbs, traffic, etc. Show a good example by following all safety recommendations.*

*Avoid direct contact with sea water and your equipment. Wipe off any sea spray particles or sand whenever possible. Calcium can quickly damage important component of your trike.*

*Always lock the trike to an immovable object with a high-quality bicycle lock when left unattended. It is also recommended to lock any component with a quick release attachment device.*

*Take note of your product serial number and store it somewhere secured. This unique identification number can be required by Trivel customer service for warranty purpose. It can also help proving your ownership of the equipment to your insurance company or local police service in case it is stolen.*

*This product may contain chemicals known to the state of California to cause cancer and birth defects or other reproductive harm, including paint, lubricants, and various metals. Wash hands thoroughly after handling this product. (California Prop 65)*

## Riding safely

Improve the safety of the user taking place on the trike and reduce the risk of injuries resulting from a fall by following these recommendations.

### Check the trike before each ride

Proceed to a safety check of the trike and its components. Take a special attention to the seat adjustments and tightening handles for any loosening. If in doubt, please have a qualified technician look over the trike for assessment before using.

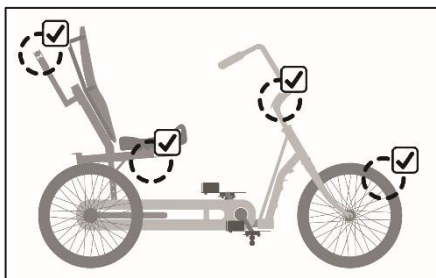

### Control the speed

Keep control of the trike at all time. Avoid going too fast, especially when turning as this could lead to a risk of capsizing.



### Ride on level ground

Avoid riding on inclines to prevent risk of tipping.



### Keep away from hazardous situations

Avoid riding near dangerous areas such as slopes, staircases, ramps, public road, etc.



*Children should be supervised by a responsible adult at all time when riding a trike.*



*It is the responsibility of the adult supervisor to identify and assess the dangers of a situation to prevent accident.*

## Before your first ride

Congratulations, you are about to experience a great feeling; riding a Trivel! To ensure you have a pleasant first ride, please make sure to follow these simple instructions:

1. Read or have someone read to you this manual's [Safety Warnings](#) and [Riding Basics](#) sections. Only until these sections have been fully understood it is recommended to go for your first ride.
2. Adjust the seat, backrest, and handlebars to the recommended position for you. See [Adjusting your Trivel](#) section to learn how.
3. Proceed to a safety check on the equipment. See [Equipment Safety check](#) on the following chapter.

You're good to go! Put your helmet on and enjoy the ride!



It is strongly recommended that you choose a private or closed-circuit road without major inclines or vehicles get to know how your Trivel handles and how control components such as the brakes feel.

## Before each ride

- ✓ Check and tighten handles under the seat if there's any movement when rocking the seat side to side.
- ✓ Check and tighten the seat post tightening set screws in the frame's square seat tube if there's any movement when rocking the seat side to side.
- ✓ Check the parking brake function (Model T350) by pulling the brake lever and engaging the locking push pin. Adjust cable tension if needed. See [Adjusting cable tension](#) section for instructions.
- ✓ Check the front brake function by pulling the brake lever and making sure there is no movement when pushing the tricycle back and forth. Adjust cable tension if needed. See [Adjusting cable tension](#) section for instructions.
- ✓ Visually inspect the frame and all components of the tricycle for signs of damage or material failure. If you suspect a component is damaged or if the frame shows a sign of failure (such as a crack, or permanent deformation), do not ride the tricycle before it has been inspected and assessed by a qualified technician.

## Adjusting the seat

Your Trivel offers a wide range of adjustment when it comes to set the seat position. Whether you need a lower relaxed position or a more active upright position, our two-axis adjustable seat can be set to virtually any combination within the adjustment range.

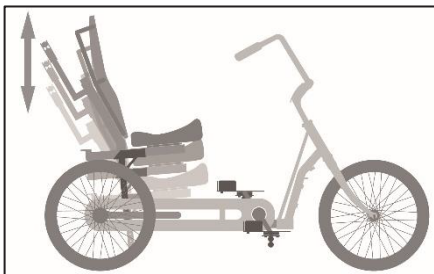
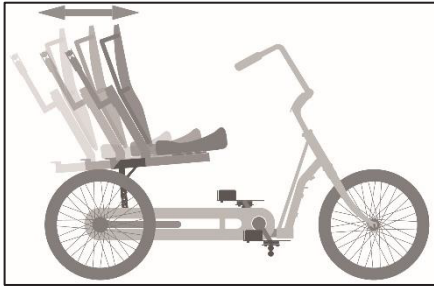

## Recommended rider position

Although every rider has their preference and their condition may command specific requirements, it is generally recommended to firstly base the desired position choice in regard to the rider's inseam (leg length from the crotch).

The rider's leg when the pedal is at its farthest position from the seat should be only slightly bent at an approximate angle of 20 degrees.

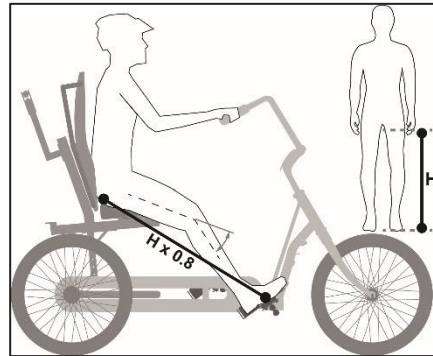

*You can quickly set the seat at the recommended position by multiplying the rider's inseam height (H) by 0.8 and using the result to move the seat away to that distance from the pedal axle (at its farthest position).*



*When the user requires to transfer or to be transferred from a wheelchair or other device, it is recommended to set the Trivel seat height to match that of the wheelchair or other device.*



*Always check for proper tightness of all clamps and handles before using the tricycle. Refer to the torque chart in appendix for reference.*



## Seat height adjustment

### To raise or lower the seat:

#### Model year 2017-2018:

1. Loosen both seat post tightening set screws in the frame's square seat tube

*Lift and hold the seat up, then:*

2. Undo the seat post collar screw and knob from the initial hole
3. Reposition the seat post collar at the desired height
4. Screw the bolt and knob back in the seat post collar

*Insert the seat post back into the frame until the collar sits on the seat post clamp upper edge, then:*

5. Firmly tighten the seat post tightening set screws

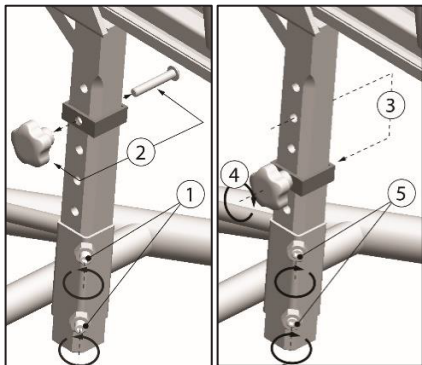

#### Model year 2019:

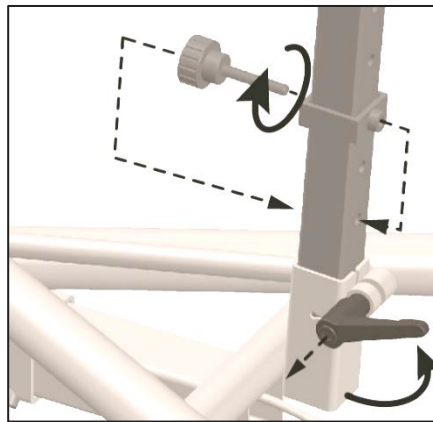

1. Loosen the frame's square seat post clamp handle

*Hold the seat up, then:*

2. Undo the seat post collar knob from the initial hole
3. Reposition the seat post collar at the desired height



*Check and retighten the tightening screws / handle if needed before every ride as the natural flexing of the seat post often cause them to loosen.*

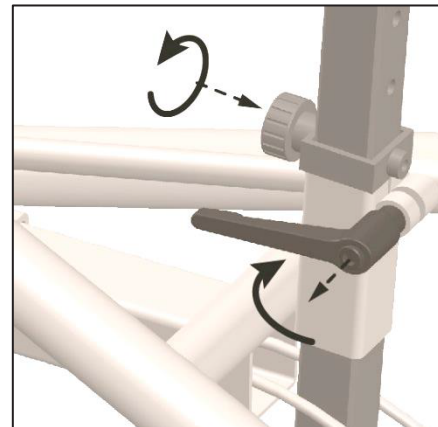

4. Screw the knob back in the seat post collar

*Insert the seat post back into the frame until the collar sits on the seat post clamp upper edge, then:*

5. Firmly tighten the seat post clamp handle

### Seat reach adjustment

#### To move the seat back or forth:

1. Loosen both left and right tightening handles. under the seat.

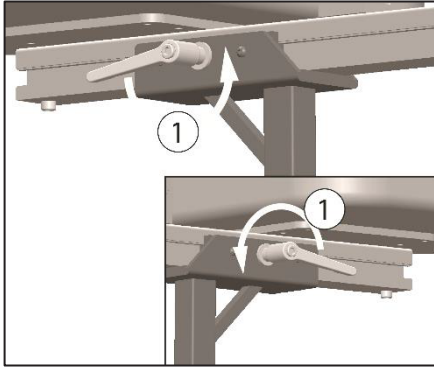

2. Firmly push or pull the seat unit to the desired position.

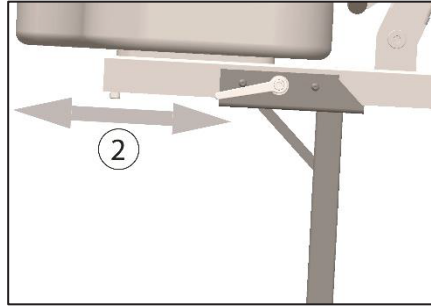

3. Lock the seat in place by firmly tightening the handles.

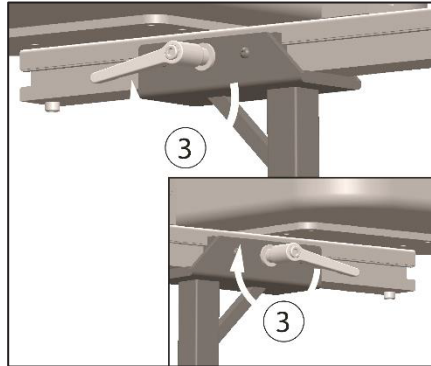

### Back support angle adjustment

The back-support incline angle can be precisely adjusted through a wide range for the user's comfort or his specific medical condition requirements.

#### To adjust the back-support incline angle:

1. Pull and hold the lever actuating the gas spring.
2. Firmly push or pull the back support to the desired angle.
3. Release the lever to lock the back-support in position

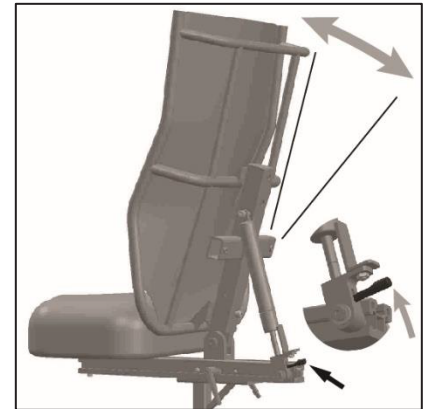

*Check and retighten the tightening handles if needed before every ride as the normal flexing of the seat post often cause them to loosen.*

## Adjusting the pedal heel support

The heel supports included with the tricycle can be adjusted to fit the user's size and specific medical condition.

Trivel offers a wide range of options for additional heel and leg support. Contact your retailer or visit Trivel website to know more.

### To adjust the heel supports width:

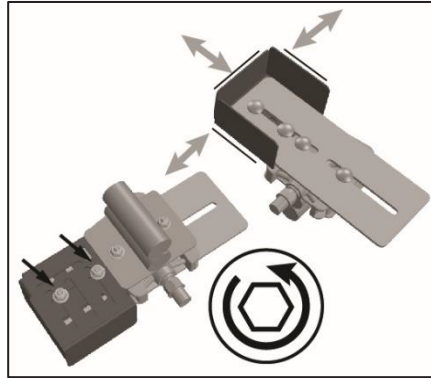

- Loosen the carriage bolt nuts from under the heel support
- Reposition the lateral heel supports to desired width

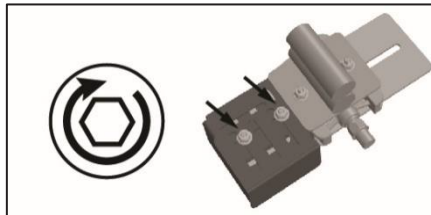

- Tighten the nuts to lock the lateral heel support in position

### To adjust the heel support position:

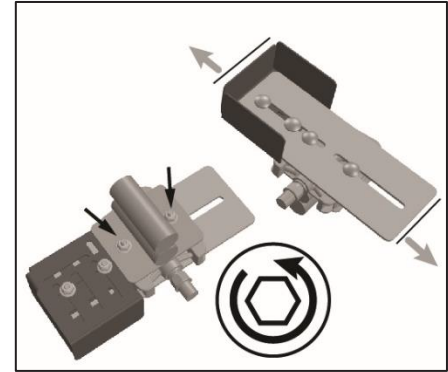

- Loosen the carriage bolt nuts from under the pedal
- Reposition the heel support to the desired position

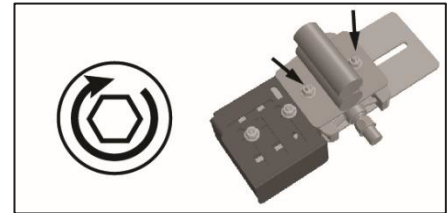

- Tighten the nuts to lock the lateral heel support in position

## Adjusting the pedals distance

The crank arms on the tricycle offers two position options for the pedals to be fitted.

Whether the user's leg extension requires shorter or longer deployment while pedaling or in the case of a short leg condition, the pedal's position can be customized.

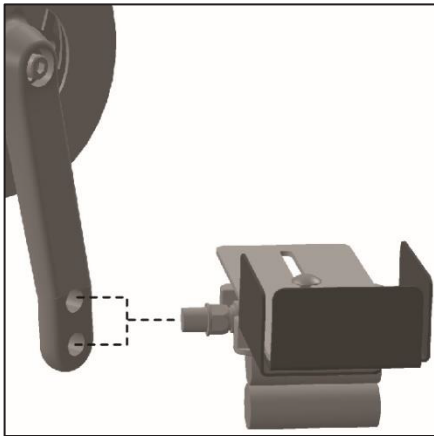

### To change the pedals position:

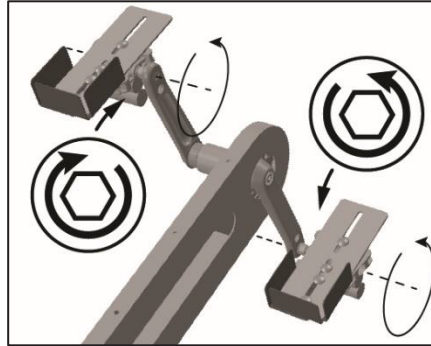

- Unscrew the pedal from the crank arm  
*(Read the important note below)*



*Note that the left pedal's axle (left hand side when sitting on the tricycle) has a reversed thread. This means it needs to be unscrewed by turning clockwise. Right pedal's axle has regular threads; it can be unscrewed by turning counter-clockwise.*

- Remove the plastic plug from the second hole in the crank arm.

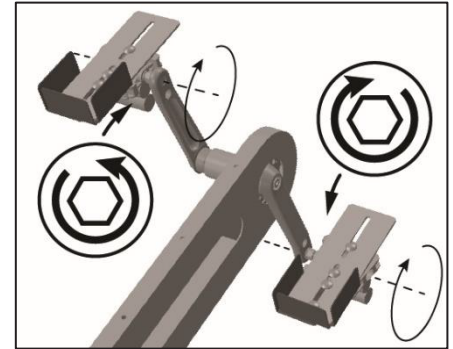

- Screw the pedal into its new position.  
*(Read the important note below)*
- Replace the plastic plug



*The pedal's axle threads are very fine and the crank arm's material can be damaged if no care is taken when engaging the pedal's axle threads. Do not force the threads if the pedal gets harder to screw or stuck as this will permanently damage the crank arms threads.*



*Note that the left pedal's axle (left hand side when sitting on the tricycle) has a reversed thread. This means it needs to be screwed by turning counter-clockwise. Right pedal's axle has regular threads; it can be screwed by turning clockwise.*

## Adjusting the stem

Following the initial assembly of the tricycle, some final ergonomic adjustment still needs to be done according to the user's specific needs.

The stem can be adjusted in two ways independently (height and angle). Feel free to determine which configuration works best for you and the user.



*The stem is part of the steering system of the tricycle. It is necessary to ensure it is properly fitted. Always check for safe tightness of the stem before use.*

## Stem height adjustment

### To lift or lower the stem:

- Push the safety button down and lift the lever

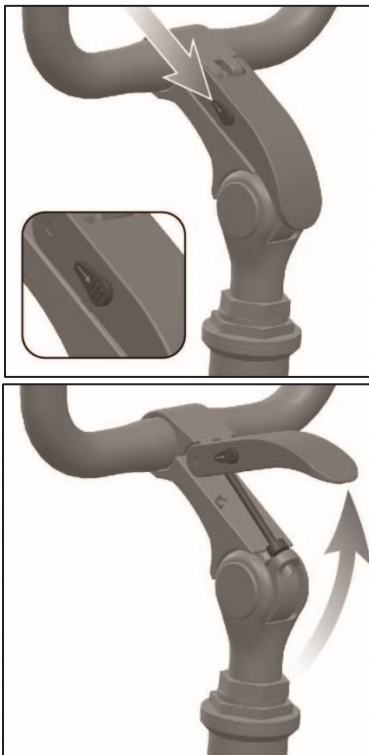

*Identify the safety minimum insertion mark engraved on the stem quill. Make sure the mark remains hidden inside the head tube at all time.*

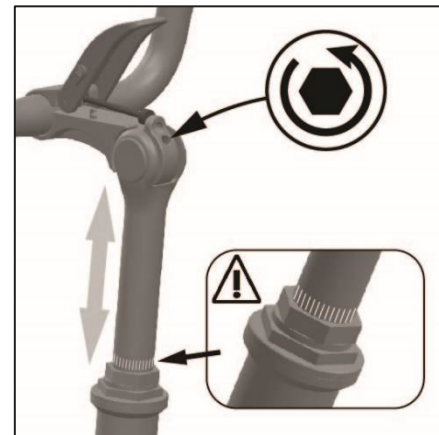

1. Loosen the stem quill bolt using a long 6mm Allen key
2. Position the stem at the desired height
3. Firmly tighten the stem quill bolt with the long 6mm Allen key (20 Nm)



*Before tightening the stem in position, make sure it is aligned with the front wheel.*

### Stem angle adjustment

#### To change the stem angle:

- Push the safety button down and lift the lever

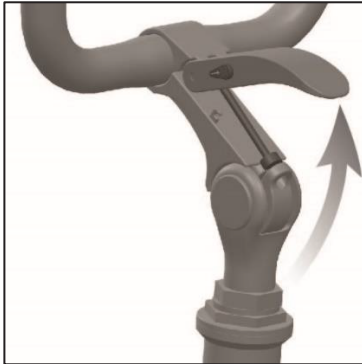
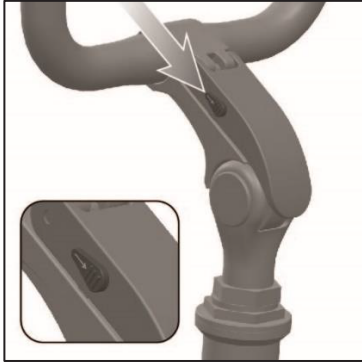

- Rotate the stem to the desired angle

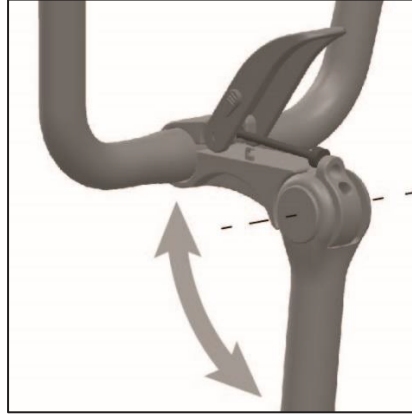

*Be careful not to let the handlebar fall heavily when you open the stem clamp to prevent damage to the frame or injury.*

- Firmly push the lever until the safety button clicks in place, confirming a tight clamp is achieved



## Positioning the front handlebar

The front handlebar can be rotated closer or further from the user so he or she can reach the grips more easily.

### Opening the stem clamp

#### To open the stem clamp:

- Push and hold the safety button

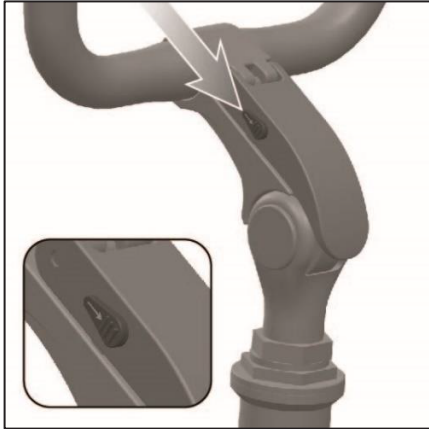

- Pull the stem tightening handle up, releasing the mechanism

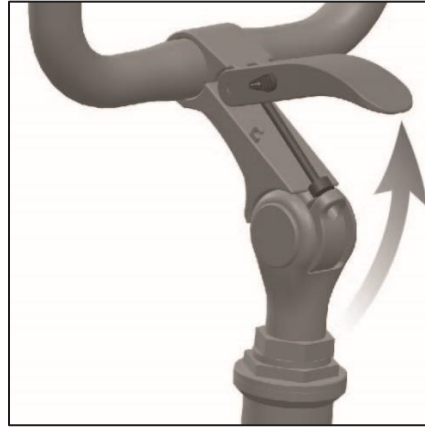

### Positioning the handlebar

- While the stem clamp is opened, rotate the handlebar forward or backward to the desired position at a comfortable reach for the user



*Careful not to let the handlebar fall heavily when you open the stem clamp to prevent damage to the frame or injury.*

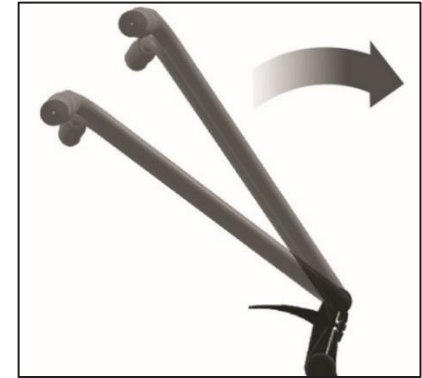

*Before tightening the stem, make sure the handlebar is centered inside the stem clamp*

- Firmly push the stem tightening handle until the safety button clicks in place

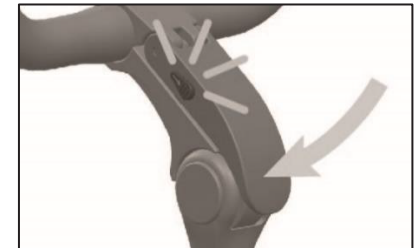

## Transferring a user

Trivel tricycles allows for easy user transfer thanks to the adjustable seat and the great amount of clearance when the front handlebar is released and moved away.

Make sure the tricycle is equipped with all the retaining equipment needed for the user's condition.

Trivel offers a wide range of accessories for supporting the user body. Contact your retailer or visit Trivel website to know more.



*Always follow the instructions of a medical specialist when transferring a user to a Trivel tricycle seat.*



*Always engage the parking brake before proceeding to the user transfer.*

## Engaging the parking brake

### Trivel T350:

Firmly pull the right brake lever until the spring-loaded push button on the lever body can be pushed down entirely.

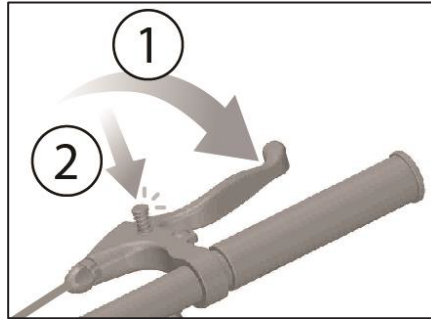

### Trivel T250:

Pull the handle next to the brake lever until it sits and locks into tensioned position.

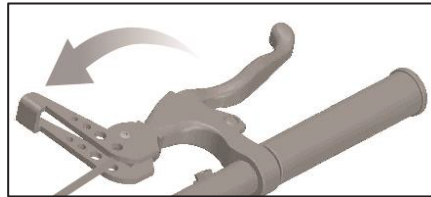

*Verify the parking brake's function by pushing the trike back and forth and make sure the wheel remains locked. Adjust brake cable tension if necessary.*

Refer to section [Brake adjustment](#) for instructions on how to adjust brake cable tension.

## Adjusting the seat height

Matching the tricycle's seat height with the user's seating device will make it easier to proceed to the transfer.

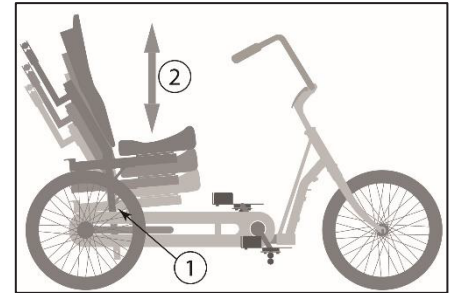

Refer to section [Seat height adjustment](#) for the instructions on how to change the seat's height.



### *Releasing the handlebar*

To add significant space for a safe and efficient transfer of a user to the tricycle's seat, it is recommended to release and move away the handlebar temporarily.

The stem, holding the handlebar in place, is designed to be opened without a tool so that the handlebar can be moved away allowing maximum clearance for transfer.

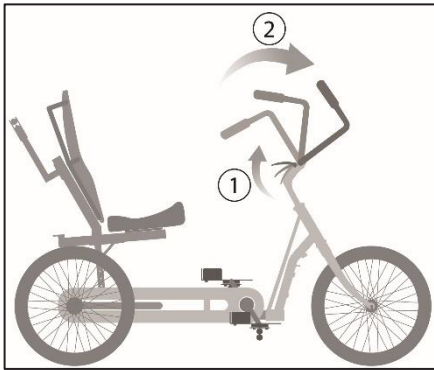

For detailed instructions on how to release the handlebar, refer to the section [Positioning the handlebar.](#)

### Fitting and adjusting the lateral supports

Lateral supports can be fitted and adjusted to the user whether he or she needs more or less of a snugged support.

#### **To fit and adjust the lateral supports:**

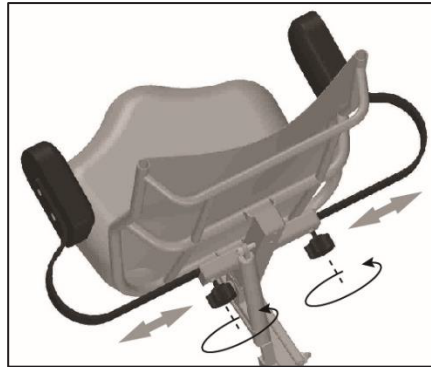

- Loosen the threaded knobs on the housing so the lateral support's blade can slide in freely
- Slide the lateral supports into the housings until desired position
- Tighten the threaded knobs to lock the lateral supports in position

## Adjusting the guide bars

For users requiring lateral leg support, Trivel offers a set of highly adjustable guide bars.

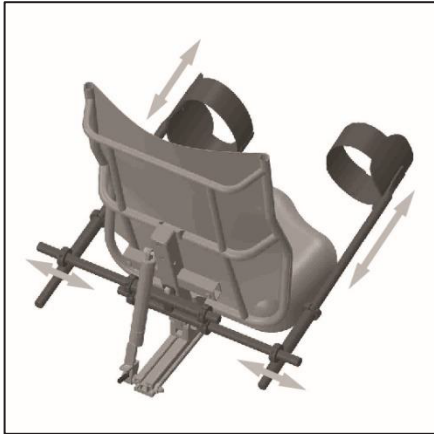

### To adjust the guide bars:

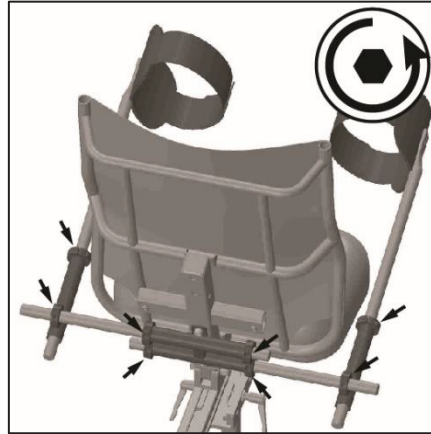

1. Loosen all housing clamp's bolts until the shafts can slide freely
2. Open the thigh straps by pulling apart the Velcro bands
3. Wrap the bands around the user's thigh at the desired position.

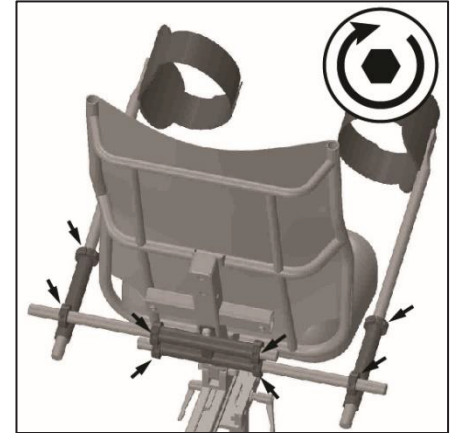

4. Tighten all housings clamp's bolts to lock the guide bars in position

## Fitting the abductor pommel

Trivel trikes can be fitted with an abductor pommel designed to stabilize a user with movement disorders.

### To fit the abductor pommel:

- Unscrew the safety bolt under the seat beam
- Fit the metal shim into the seat beam, aligning both holes.

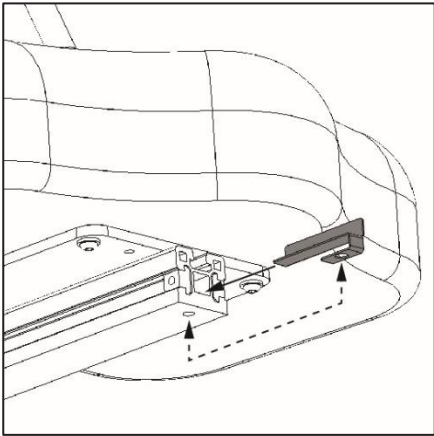

- Insert the abductor pommel shaft into the seat beam to the desired position.
- Screw the knob bolt into the threaded hole. Tighten by hand to fix the abductor pommel in position.

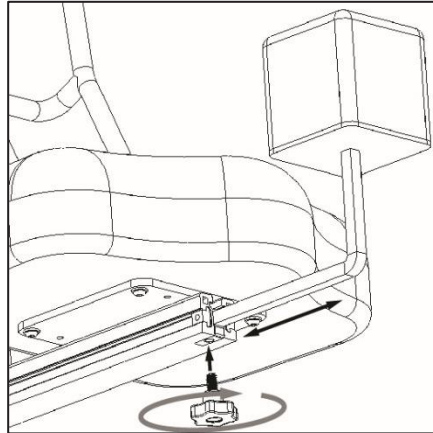

## Fixed / Freewheel drive modes

T250 and T350 trikes comes standard with two drive modes that allows the user or a helper to switch between a fixed drive mode (with constant direct engagement of the pedals to the rear wheels in both forward and rearward motion) or a freewheel drive mode (with engagement of the pedals in forward motion only and the ability to stop pedaling while the trike is still moving forward).

The mechanism that allows to switch between drive modes is located at the back of the trike, on the rear axle, on the left-hand side next to the chain guard.

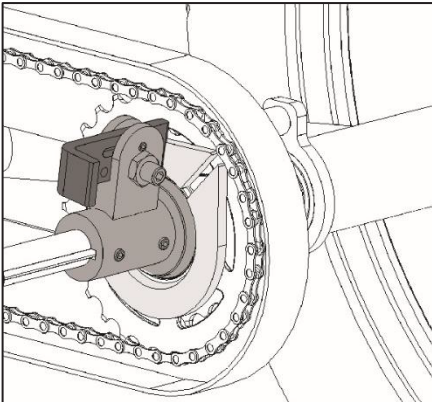

*Only operate the mode switching mechanism when no one is sitting on the trike as this increases the risk of finger entrapment and injury.*



*There is a risk of finger entrapment and injury when operating the mode switching mechanism. Be careful when handling the lever and keep away from the chain and gears at all time.*



*Only a responsible supervising adult should operate this mechanism. It is his or her responsibility to understand the difference in the different drive modes and to communicate the change in pedaling behavior it creates to the person sitting on the seat.*

## Fixed drive mode

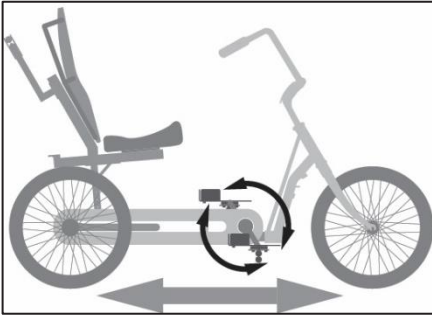

With the fixed drive mode engaged, the user can pedal to propel the trike forward or backward. The user's legs will always be moving along with the trike, following the chainwheel rotation as the trike moves forward or backward.



*It is strongly recommended to use heel supports when using the fixed drive mode to prevent a loss of control and/or injuries.*

To engage the fixed drive mode:

Step 1:

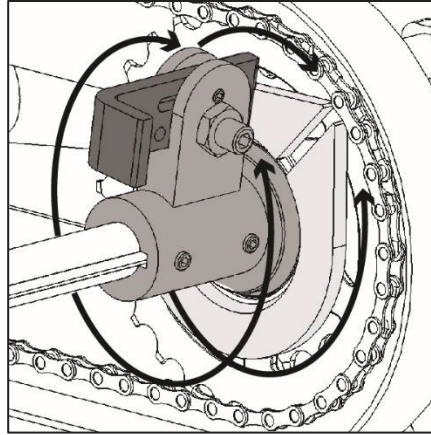

Align the freewheel disc slot with the locking lever by pulling the trike from the back towards you or by rotating the pedals backwards until they are both aligned.

Step 2:

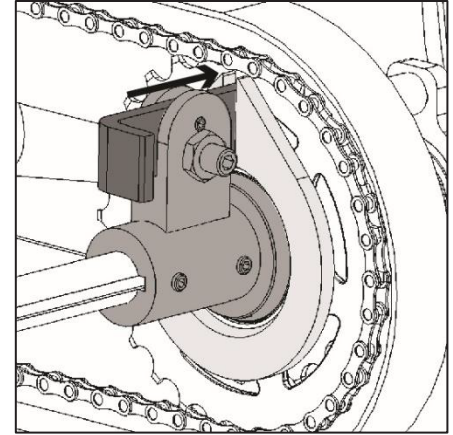

Push the lever to the right into the freewheel disc slot.

### Freewheel drive mode

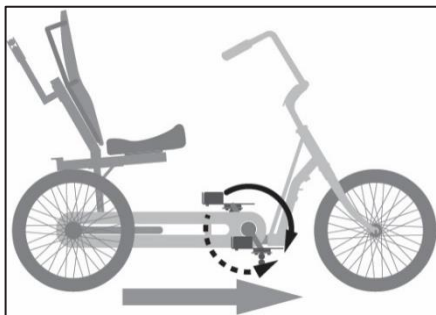

With the freewheel drive mode, the user can still propel the trike when pushing forward on the pedals but can rest and coast when desired while the trike keeps moving forward.

### To disable the fixed drive mode:

#### Step 1:

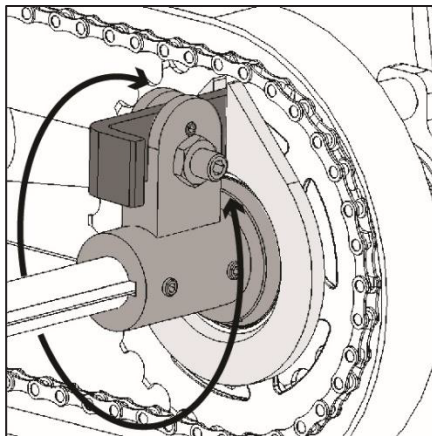

Push or pull the trike from the back until the lever is safely accessible.

#### Step 2:

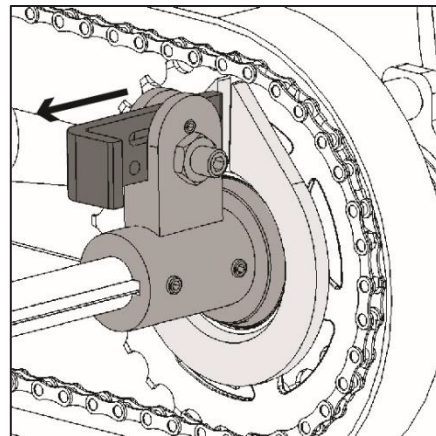

Pull the lever to the left, out of the freewheel disc slot.



*Be aware and always advise the user that the pedals will rotate backwards whenever the trike is being pulled from the back by a helper.*



*There must always be a responsible supervising adult operating the rear steering handlebar when the trike is set on Freewheel drive mode.*

## Advanced adjustments

### Brake cable tension adjustment

When the brake pads material wears down, the gap in between them and the wheel increases. The cable tension then needs to be adjusted accordingly to preserve proper braking force.

#### To increase cable tension:

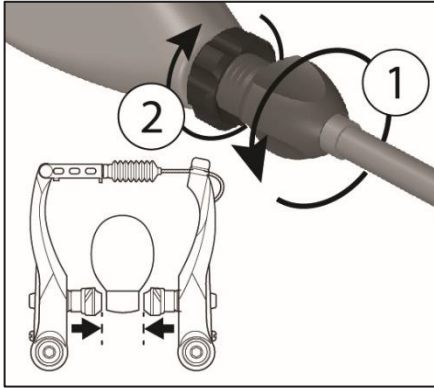

1. Turn the barrel adjuster counter clockwise to pull cable
2. Lock the adjustment by screwing the locknut clockwise

In the opposite case, when the brake pads are too close to the wheel, preventing its freely rotation, or making it impossible for the parking brake push button to engage, the cable tension then needs to be reduced.

#### To reduce cable tension:

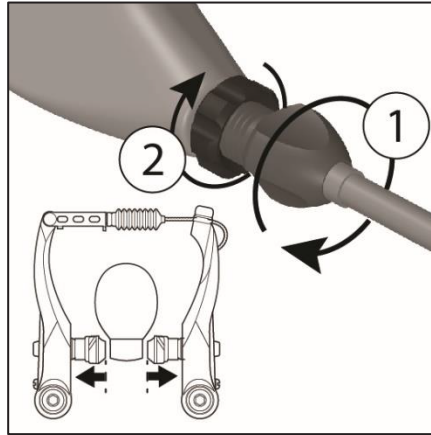

1. Turn the barrel adjuster clockwise to let some cable go
2. Lock the adjustment by screwing the locknut clockwise

### Rear steer cable tension adjustment

If the rear steer cable tension gets loose, there could be small delay of response in the steering or a misalignment of the front wheel with the rear handlebar. The cables tension then needs to be adjusted to eliminate the loose or to balance both cables tension to re-align the system.

#### To increase cable tension:

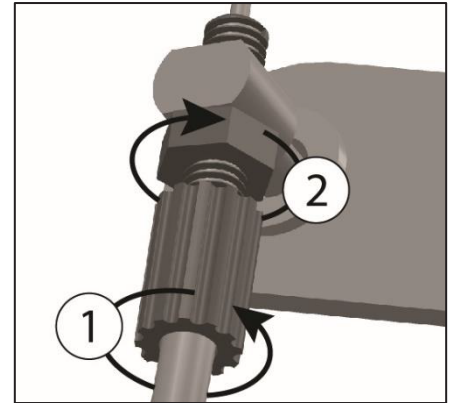

1. Turn the barrel adjuster counter clockwise to pull cable
2. Lock the adjustment by screwing the locknut clockwise

### *Stem clamp adjustment*

If the stem should fail to prevent the handlebar from moving when the lever is pushed down and engaged, the tightening mechanism may need to be adjusted.

#### **To increase the stem's clamping action:**

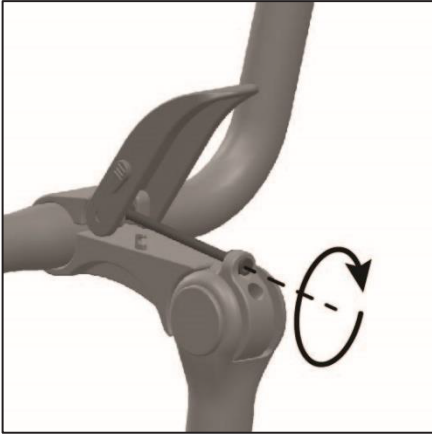

While the mechanism is opened, gently tighten the adjustment bolt to reach a sufficient clamping force for the handlebar not to be able to rotate while still being able to push and pull the lever with reasonable force.

## **Warranty terms and limitations**

By the present, Trivel gives notice to the owner or the user of a Trivel T350 or Trivel T250 trike of the provisions of the limited warranty that Trivel offers the owner following the purchase of the equipment from an authorized Trivel dealer.

### **Warranty against hidden defects**

Trivel warrants to the owner that its equipment, when new, is exempt from hidden defects. Should the owner discover what he believes is a hidden defect, he must notify Trivel in writing within three (3) days from the moment when he or she first becomes aware of said defect in order to give Trivel the opportunity to correct said defect if possible, at the sole discretion of Trivel and provided Trivel can establish said hidden defect is present before the expiration of the warranty.

### **Warranty against apparent anomaly**

The owner must verify the apparent condition, the quantity and the contents of the equipment following the purchase and, on the same day, must immediately proceed with a complete inspection of it with the

help from the owner's manual. If there is damage, if a part is missing or is damaged, if the equipment is broken, or if there are other problems of the same kind (hereafter known as: 'Apparent anomaly'), the owner must contact the dealer immediately and notify Trivel within three (3) days from the date of purchase from the dealer by registered letter, a receipt for which must be kept for reference. Should the owner not advise of the Apparent anomaly within the prescribed time period, Trivel shall not be responsible for any prejudice suffered by the owner due to the Apparent anomaly and the equipment shall be deemed free of any Apparent anomaly when purchased and the owner deemed satisfied with the purchase.

### **Frame**

Trivel warrants to the owner that the trike frame when new, is free from defects in materials and workmanship. This warranty shall expire thirty-six (36) months following the purchase date of the equipment from the dealer. The frame excludes the paint and finish, the front fork, the wheels, the tires, the drive train, the brakes, the saddle post,



the handlebar and stem and any suspension component or part.

### **Useful life warranty**

As for any other consumer good, a Trivel trike has a useful life cycle. The length of the useful life cycle can vary depending on the criteria chosen for workmanship and materials of the equipment as well as the kind of use and frequency to which the vehicle has been subjected. However, Trivel advises the owner that the maintenance and upkeep performed on the equipment during its useful life cycle are very important as a means of prolonging the useful life cycle of the product. Consequently, Trivel advises the owner that the equipment must be checked periodically by the dealer as general maintenance of the product and as a means of detecting stress and/or potential failures including, but without limiting the generality of the preceding, cracks, deformations, corrosion, paint chipping, dents and any other indications of potential problems, improper use or abuse. These regular verifications are important safety checks and they are essential in helping to prevent accidents, bodily injury and premature

reduction of the useful product life cycle of the equipment.

### **Merchandise return policy during warranty period**

If a defect occurs during the warranty period, the parts will have to be shipped to Trivel directly from an authorized Trivel retailer and, following repairs, Trivel shall ship the parts back without charge to the retailer exclusively. If the shipping address is different than the nearest Trivel retailer's the customer shall have to pay shipping costs both to and from said different address.

### **Validity of the limited warranty**

The Trivel limited warranty is conditional to the equipment having been handled and maintained adequately by the owner in accordance with the notices to the owner and the instructions printed in the owner's manual and on the equipment having been stored in appropriate conditions. To be able to benefit from the terms and conditions of the limited warranty offered by Trivel, the owner must fill a Trivel limited warranty form (which can be found at an authorized

Trivel dealer and on Trivel website) and return it to the dealer with a copy of the invoice obtained at the time of purchase to Trivel within thirty (30) days of the purchase date.

Without limiting the generality of the preceding, the Trivel limited warranty excludes components of the vehicle that are damaged by an error or negligence in the maintenance of the equipment and its components or resulting from a use that does not conform to the notice to the owner and to the Trivel owner's manual by the owner.

DURING THE WARRANTY PERIOD, SHOULD THERE BE A PROBLEM WITH YOUR PRODUCT, YOU SHOULD HAVE REPAIRS MADE BY AN AUTHORIZED TRIVEL RETAILER IN ORDER TO CONSERVE YOUR RIGHTS UNDER THE WARRANTY.

THE WARRANTY IS NON-TRANSFERRABLE

***Please visit Trivel website for the latest version of this limited warranty***