



# Kid Kart Xpress



## Kid Kart® Xpress by Zippie®

- with transit option     without transit option

**Supplier:** This manual must be given to the user of this wheelchair.

**User:** Before using this wheelchair read this entire manual and save for future reference.

Owner's Manual

## Kid Kart® Xpress by Zippie®

- con opción de tránsito     sin opción de tránsito

**Distribuidor:** Este manual debe ser entregado al pasajero de esta silla de ruedas.

**Pasajero:** Antes de usar esta silla de ruedas, lea este manual en su totalidad y guárdelo para futura referencia.

Cada una de las sillas se envía con un manual de instrucciones en inglés. El manual en español está disponible en formato PDF en nuestra página en Internet: [www.SunriseMedical.com](http://www.SunriseMedical.com). Ingrese a la página del producto específico para descargar el manual, o comuníquese con el proveedor autorizado de Sunrise Medical.

Manual  
de Instrucciones

## Kid Kart® Xpress by Zippie®

- avec option pour transport     sans option pour transport

**Au Fournisseur :** Ce manuel doit être remis à l'utilisateur de ce fauteuil roulant.

**À l'Usager :** Veuillez lire tout le manuel et le conserver pour référence ultérieure.

Chaque fauteuil est livré avec un manuel d'instructions en anglais. La version en français est à votre disposition en format PDF sur le site : [www.SunriseMedical.com](http://www.SunriseMedical.com). Veuillez vous rendre à la page de votre produit pour télécharger le manuel dans la langue souhaitée, ou contactez un fournisseur agréé Sunrise Medical.

Manuel  
d'instructions



**SUNRISE MEDICAL LISTENS**

Thank you for choosing a Zippie wheelchair. We want to hear your questions or comments about this manual, the safety and reliability of your chair, and the service you receive from your Sunrise supplier. Please feel free to write or call us at the address and telephone number below:

**Sunrise Medical (US) LLC**  
Customer Service Department  
2842 Business Park Ave  
Fresno, CA 93727  
(800) 333-4000

Be sure to return your warranty card, and let us know if you change your address. This will allow us to keep you up to date with information about safety, new products and options to increase your use and enjoyment of this wheelchair. If you lose your warranty card, call or write and we will gladly send you a new one.

**FOR ANSWERS TO YOUR QUESTIONS**

Your authorized supplier knows your wheelchair best, and can answer most of your questions about chair safety, use and maintenance. For future reference, fill in the following:

Supplier: \_\_\_\_\_

Address: \_\_\_\_\_  
\_\_\_\_\_

Telephone: \_\_\_\_\_

Serial #: \_\_\_\_\_ Date/Purchased: \_\_\_\_\_

**ADDITIONAL INFORMATION YOU SHOULD KNOW**

No component of this chair was made with natural latex rubber

**DISPOSAL AND RECYCLING INFORMATION**

When this product reaches the end of its life, please take it to an approved collection or recycling point designated by your local or state government. This wheelchair is manufactured using a variety of materials. Your product should not be disposed of as ordinary household waste. You should dispose of your wheelchair properly, according to local laws and regulations. Most materials that are used in the construction of this product are fully recyclable. The separate collection and recycling of your product at the time of disposal will help conserve natural resources and ensure that it is disposed in a manner that protects the environment.

Ensure you are the legal owner of the product prior to arranging for the product disposal in accordance with the above recommendations.

<b>III. YOUR DEVICE AND ITS PARTS .....</b>	<b>4</b>
<b>IV. NOTICE– READ BEFORE USE .....</b>	<b>5</b>
<b>V. GENERAL WARNINGS .....</b>	<b>5</b>
A. Weight Limit.....	5
B. Getting to know your device .....	5
C. To reduce the risk of an accident .....	5
D. Safety checklist .....	5
E. Changes and adjustments .....	5
F. Environmental conditions .....	6
G. Street use.....	6
H. Motor vehicle safety.....	6
I. For caregivers .....	6
<b>VI. WARNINGS: FALLS &amp; TIP-OVERS .....</b>	<b>6</b>
A. Center of balance .....	6
B. Dressing or changing clothes .....	6
C. Obstacles .....	6
D. Reaching or leaning .....	7
E. Ramps, slopes and sidehills.....	7
F. Transfers .....	7
G. Negotiating A curb or single step .....	7
H. Climbing stairs .....	7
I. Descending stairs .....	8
J. Escalators.....	8
<b>VII. WARNINGS– COMPONENTS &amp; OPTIONS.....</b>	<b>8</b>
A. Base Frame .....	8
B. Upper Extremity Support Tray .....	8
C. Fasteners .....	8
D. Anti-tip tubes.....	8
D. Footrest.....	9
E. Tires and Wheels.....	9
F. Parking Brake .....	9
G. Undercarriage Storage.....	9
H. Accessory Trays .....	9
I. Canopy .....	9
J. Seating Systems .....	9
K. Pelvic Positioning Belts .....	9
L. Cushions .....	9
M. Tilt and Recline .....	10
N. Transit Option and Use.....	10
<b>VIII. USE &amp; MAINTENANCE.....</b>	<b>11</b>
A. Maintenance and Safety Notes.....	11
B. Cleaning .....	11
C. Storage Tips .....	11
D. Safety Checklist.....	11
E. Rear Wheel Removal and Installation .....	12
F. Wheel Locks .....	12
G. Unfold and Fold .....	12
H. Positioning Shell Installation.....	14
I. Positioning Shell Removal.....	14
J. Tilt in Space Angle Adjustment .....	15
K. Hip Angle Adjustment.....	15
L. Recline Adjustment (optional) .....	15
M. Knee Angle Adjustment .....	16
N. Canopy Installation and Adjustment .....	16
<b>IX. DEALER SERVICE &amp; ADJUSTMENT .....</b>	<b>18</b>
A. Positioning and Growth Adjustments.....	18
B. Seat Depth Adjustment .....	18
C. Standard Seat Cushion Adjustment.....	18
D. Contour Cushion Seating Adjustments .....	19
E. Standard Cushion w/o Lateral Supports .....	19
F. Back Positioning Plate Height Adjustment.....	19
G. Back Cushion Height Adjustment .....	19
H. Footbed adjustments .....	20
I. Pelvic Positioning Belt Adjustments.....	20
J. Anterior Trunk Butterfly Support.....	21
K. Lateral Trunk Supports .....	21
L. Hip Pads.....	22
M. Knee Adductors .....	22
N. Abductor Pad.....	23
O. Anterior Supports .....	23
P. Head Supports.....	24
Q. Tray Arm Height Adjustment .....	25
R. Tray installation and adjustment.....	25
S. Shoe Holder Foot strap adjustment.....	25
<b>X. SUNRISE LIMITED WARRANTY .....</b>	<b>27</b>



**ZIPPIE XPRESS**

- 1. Wheel locks
- 2. Safety Lockout pin
- 3. Recline Control(optional)
- 4. Handle Adjustment
- 5. Transit Option securement
- 6. Footbed adjustment
- 7. Anti-tip tubes
- 8. Sunshade adjustment
- 9. Positioning shell
- 10. Mobility base
- 11. Tilt in Space block
- 12. Tilt in Space adjustment
- 13. Tray Support
- 14. Handle Extension Trigger

All features may not be available with some device setups or in conjunction with other device features. Please consult your supplier for more information. Your authorized supplier can also provide you with information on accessories.

**Weight:**

**Total: 34 lbs      Shell only: 16 lbs**  
**Base only: 18 lbs**

**Color Options:**

**Frame:** Silver , Purple, Soft Pink.  
**Seating shell fabric:** Green, Navy Blue  
 Orange Butterflies, Red race flags  
**Seat & Back fabric:** Black (US only)  
 Gray, Navy

**Adjustment Ranges:**

**Tilt:** 65° 20°anterior to 45° posterior

**Recline:** 85° to 130°

**Push Handle Height:** 36.5" to 41"

**Seat Depth:** 5.5" to 11"

**Seat Width (at hip):** 12.5"

**Width with optional Lateral hip supports:**  
 6.5" to 10"

**Knee Width:** 13"

**Width with optional Lateral knee supports:**

5" to 11"

**Top of head to seat:** 13" to 22"

**Top of shoulder to seat:** 7.5" to 16"

**Axilla (under arm) to seat:** 4.5" to 12"

**Chest width:** 4" to 10"

**Width of head:** 3.75" to 7"

**Shoulder width:** 5" to 11"

**Lower Leg/Foot:** 5" to 14"

**Footbed adjustment:** 70° to 170° extension

**Dimensions**

Overall width: 24" (65cm)

Floor-to-seat height: 21"

**Seating Options**

Standard Cushion w/o Lateral hip spprt

Adjustable contour cushion w/o lateral hip support.

**A. CHOOSE THE RIGHT DEVICE & SAFETY OPTIONS**

Sunrise provides a choice of many wheelchair styles to meet the needs of your child. However, final selection of the type of device, options, and adjustments rests solely with you and your health care advisor. Choosing the best early intervention device and set-up for safety depends on such things as:

1. The child's disability, strength, balance, coordination, and the limits of their abilities.
2. The types of hazards that must be overcome in daily use (where you live and work), and other places you are likely to use the device.
3. The dependents need of options for their safety and comfort.

**INTENDED USE:** The Zippie Xpress is intended for medical purposes to provide mobility to persons under 55lbs(25kg) restricted to a sitting position.

**B. REVIEW THIS MANUAL OFTEN**

Before using this device you, and each person who may assist you, should read this entire manual and make sure to follow all instructions. Review the warnings often, until they are second nature to you.

**C. WARNINGS**

The word "**WARNING**" refers to a hazard or unsafe practice that may cause **severe injury or death** to you or to other persons. The "Warnings" are in three main sections, as follows:

**1. V — GENERAL WARNINGS**

Here you will find a safety checklist and a summary of risks you need to be aware of before you ride this device.

**2. VI — WARNINGS — FALLS & TIP-OVERS**

Here you will learn how to avoid a fall or tip-over while performing daily activities with the device.

**3. VII — WARNINGS — FOR SAFE USE**

Here you will learn about practices for the safe use of the device.

**4. VIII — WARNINGS — COMPONENTS & OPTIONS**

Here you will learn about the components of the device and options you can select for safety. Consult your authorized supplier and your health care advisor to help you choose the best set-up and options for safe use.

**NOTE** - Where they apply, you will also find "Warnings" in other sections of this manual. Heed all warnings. If you fail to do so, a fall, tip-over or loss of control may occur and cause severe injury to the rider and/or others.

## V. GENERAL WARNINGS

**A. WEIGHT LIMIT****⚠ WARNING**

NEVER exceed the weight limit of 55 pounds (25 kg), for the weight of the occupant. If the limit is exceeded, damage to your device, a fall, tip-over or loss of control may occur and cause severe injury to the rider and/or others. Never hang items greater than 5lbs (2.3kg) from stroller handle or seat back handle. A fall, tip-over, or loss of control may occur.

**B. GETTING TO KNOW YOUR DEVICE****⚠ WARNING**

Read all instructions before using this product. In particular, you should be trained in the safe use of this product by your health care professional.

**C. TO REDUCE THE RISK OF AN ACCIDENT****⚠ WARNING**

1. BEFORE using this device, you should be trained in its safe use by your health care professional.
2. Practice transfers until you know your limits and the extent of your child's abilities. Always ask if you need to have someone help you to avoid a fall or tip-over.
3. Be aware that you must develop your own methods for safe use best suited to your level of function and ability.
4. NEVER try a new maneuver on your own until you are sure you can do it safely.
5. Get to know the areas where you plan to use your device, look for hazards and learn how to avoid them.

**D. SAFETY CHECKLIST****⚠ WARNING**

Before each use of the Early Intervention Device.

1. Parking brake must be adjusted to maintain proper performance. Always engage the parking brake before transferring a dependent child.
2. Check that the device rolls easily, and that all parts work smoothly. Check for noise, vibration, or a change in ease of use, (they may indicate loose fasteners, or other damage).
3. Repair any problem you may encounter. Your authorized supplier can help you find and correct any problems.
4. Make sure the tire/axle on both sides are fully engaged and locked. If they are not locked, the wheel may come off and cause a fall.
5. Never seat your child in the mobility device until it is fully unfolded and locked.
6. After adjusting handle length check to make sure that it is locked at the new length.
7. Always use a pelvic positioning belt when child is seated.
8. Never leave your child unattended.

**E. CHANGES AND ADJUSTMENTS****⚠ WARNING**

1. If you modify or adjust this chair, it may increase the risk of a tip-over UNLESS you make other adjustments as well.
2. Consult your authorized supplier BEFORE you modify or adjust your chair.
3. We recommend that you use anti-tip tubes until you adapt to the change, and are sure you are not at risk to tip over.
4. Unauthorized modifications by the end-user, dealer or any other individual, including the use of parts not supplied or approved by Sunrise may change the chair structure. This will void the warranty and may cause a safety hazard.

**F. ENVIRONMENTAL CONDITIONS****⚠️ WARNING**

1. Your mobility device is designed for use on firm, even surfaces such as concrete, asphalt, indoor floors and carpeting.
2. Use extra care if you must use this mobility device on a wet or slick surface. If you are in doubt, ask for help.
3. Do not operate your mobility device in sand, loose soil or over rough terrain.
4. Do not use this product in a shower, pool or other bodies of water.

**G. STREET USE****⚠️ WARNING**

1. When using this device, avoid street use whenever possible.
2. This product should stay in, and obey all legal pedestrian pathways, and laws that apply to pedestrians.
3. Be alert to the danger of motor vehicles in parking lots.
4. At night, or when lighting is poor, use reflective tape or clothing for maximum visibility.
5. If you have to cross a road, make eye contact with drivers before you go forward. When in doubt, yield until you are sure it is safe.

**H. MOTOR VEHICLE SAFETY****⚠️ WARNING**

1. As indicated on the front cover of this user manual, identify whether your device has been manufactured with the transit option installed. If your device is NOT equipped with the transit option:
  2. NEVER use the mobility device seating system as a car seat.
  3. ALWAYS move the rider to an approved vehicle seat.
  4. ALWAYS secure the rider with proper motor vehicle restraints

5. In an accident or sudden stop the rider may be thrown from the mobility device. Mobility device pelvic positioning belts will not prevent this and further injury may result from these belts or straps.
6. NEVER transport this mobility device in the front seat of a vehicle. This action could risk serious injury or death to the dependent rider and driver.
7. ALWAYS secure the unoccupied mobility device so that it cannot roll or shift when being transported in a vehicle.
8. Do not use this product if it has been involved in a motor vehicle accident. If your device is equipped with the transit option, refer to Section VII. "Transit Option and Use".

**I. FOR CAREGIVERS****⚠️ WARNING**

1. Work with the child's health care professional to learn safety methods best suited to your abilities and those of your child.
2. To prevent injury to your back, use good posture and proper body mechanics when lifting, or tilting your child.
3. Remind the dependent to lean back when you tilt the mobility device backward.
4. When you descend a curb or single step, slowly lower the mobility device in one easy movement.
5. NEVER leave the dependent child alone.
6. When making adjustments to the mobility device, always engage the parking brake and lock caster wheels to help minimize unintended movement.

**VI. WARNINGS: FALLS & TIP-OVERS****A. CENTER OF BALANCE****⚠️ WARNING**

Dependent mobility devices are designed for stability and performance. The point where this device will tip forward, back, or to the side depends on its center of balance and stability. The center of balance is also affected by:

- The seat height and seat angle.
- Backrest angle.
- Changes in your child's body position, postures or weight distribution.
- Pushing the mobility device on a ramp or slope.
- The use of a backpack or other options, and the amount of added weight.
- The use of a vents, batteries, oxygen and other options, and the amount of added weight that these options add to the device.

**To maintain the proper center of gravity and good balance:**

- Consult your healthcare advisor and/or supplier to help you in setting up the mobility device correctly.
- Consult your authorized supplier or healthcare advisor BEFORE you modify or adjust the mobility device.

**B. DRESSING OR CHANGING CLOTHES****⚠️ WARNING**

Your child's weight may shift if you dress your child or change your child's clothes while they are seated in the mobility device.

To reduce the risk of a fall or tip over while changing clothes or diapers:

- Rotate the front casters until they point forward.
- Engage the parking brake.

**C. OBSTACLES****⚠️ WARNING**

Obstacles and road hazards (such as potholes and broken pavement) can damage your mobility device and may cause a fall, tip over, or loss of control. To avoid these risks:

- Scan the area well ahead for danger as you travel with your mobility device.
- Make sure floor areas ahead are level and free of obstacles.
- Install a ramp at entry or exit doors. Make sure there is not a drop off at the bottom of the ramp.

**D. REACHING OR LEANING****⚠ WARNING**

If your child reaches or leans it will affect the center of balance of the mobility device. This may cause a fall or tip over.

- NEVER allow your child to reach or lean if they must rise up off their seat for the action.
- If your child must reach, move the mobility device as close as you can to the object, and rotate the front casters until they are as far forward as possible.

**NOTE-** To do this: Move your mobility device past the object that the child might want to reach, then back up alongside it.

**E. RAMPS, SLOPES AND SIDEHILLS****⚠ WARNING**

Pushing the mobility device on a slope, including ramps or hills, will change the center of balance. Some safety reminders include:

1. Do not push this product on a slope steeper than 6%. (A 6% slope means: one foot in elevation for every 16 feet of slope length).
2. Do not turn or change direction on a slope or ramp.
3. For your child's safety, ramps at home and work must meet all legal requirements for your location.
4. Always stay in the CENTER of the ramp.
5. Use a ramp with guardrails (or raised borders that are at least 3" high).
6. Always go straight up and straight down on hills or ramps.
7. Do not stop on a steep slope.
8. Watch for a drop-off at the bottom of a slope or ramp.
9. Do not engage the parking brake to slow or stop your mobility device.
10. Beware of wet or slippery surfaces, especially on slopes.
11. Do not recline or tilt the shell while going up hills.
12. Ask for help any time you are in doubt of stability.

**F. TRANSFERS****⚠ WARNING**

1. Work with your health care advisor to learn safe transfer and lifting methods.
2. Have someone help you until you know how to do a safe transfer of the dependent on your own.
3. Move your child's mobility device as close as you can to the location you are transferring to.
4. Rotate the front casters until they point forward.
5. Engage the parking brake before you transfer. This keeps the device stable during the transfer.
6. When transferring a child into the device, make sure they are placed as far back onto the seat surface as possible. This will reduce the risk that the mobility device will tip over and/or move away from you.

**G. NEGOTIATING A CURB OR SINGLE STEP****⚠ WARNING**

Follow the instructions below for descending or climbing a stair or curb. **Do not try to climb a high curb or step more than 4" high, if the accessory tray, or rear glider platform is installed.** Doing so can risk injury, may cause the device to exceed its balance point and tip over, and may cause damage to the device.

**To descend a curb or single step going FORWARD:**

1. Stay at the rear of the mobility device.
2. Several feet before you reach the edge of the curb or step, tip the device slightly backward. When the device is at its balance point, carefully step forwards until the rear wheels reach the edge of the curb or step.
3. Allow the rear wheels to slowly roll down onto the lower level. Push the chair forward until you are standing on the lower level.
4. Gently lower front casters to the ground.

**To climb a step or curb going BACKWARD:**

1. Stay behind the mobility device.
2. Continue backwards until the rear wheels contact the face of the curb or step. Lift and roll the rear wheels to the top of the curb.
3. Pull the device backwards until the caster wheels have cleared the edge of the curb and return the chair to its rolling position.

**H. CLIMBING STAIRS****⚠ WARNING**

1. Do not climb stairs if your mobility device has an accessory tray installed.
2. Use at least two attendants when moving the occupied mobility device up stairs.
3. The rider and mobility device should be facing BACKWARD when moving up the stairs.
4. ALWAYS carry the mobility device by holding the FRAME, being careful to avoid grabbing the footrest, wheels, tray parts, and other areas that are meant to detach from the mobility device.
5. The person at the rear should be in control. He or she should tilt the mobility device back to its balance point.
6. A second attendant at the front firmly grasps a non-detachable part of the front frame and lifts the mobility device up and over the stair.
7. The attendants should move up one stair at a time until the landing is reached.

**I. DESCENDING STAIRS****⚠ WARNING**

1. Do not descend stairs if your mobility device has an accessory tray installed.
2. Use at least two attendants to move an occupied mobility device down stairs.
3. Move the mobility device with both the device and rider facing FORWARD down the stairs.
4. The person at the rear is in control. He or she tilts the mobility device back to the balance point of the rear wheels and rolls it to the edge of the top step.

5. A second attendant stands on the third step from the top and grasps the frame. He or she lowers the device one step at a time by letting the rear wheels roll over the stair edge.
6. The attendants should move down one stair at a time until the landing is reached.

**J. ESCALATORS****⚠ WARNING**

NEVER use this mobility device on an escalator, even with an attendant.

**VII. WARNINGS— COMPONENTS & OPTIONS****⚠ WARNING**

This early intervention device has been tested and approved using Sunrise accessories. Any accessory that has not been expressly approved by Sunrise Medical will void your warranty, and may add a safety risk to attendant and child.

**A. BASE FRAME****⚠ WARNING**

Inspect cables and engage/release buttons before every use to make sure they are in good working condition. Be sure that your base frame is locked before seating your child.

**B. UPPER EXTREMITY SUPPORT TRAY****⚠ WARNING**

Before adding or removing a tray to the mobility device be sure to point front casters to the front of the device and engage parking brake. This keeps the wheels from rolling when attaching the tray. The support tray has a weight capacity of 50lbs.

1. Do not lift this product by its tray support arms.
2. ALWAYS make certain that the tray is fully locked into place after adding it to the dependent mobility device.

**C. FASTENERS****⚠ WARNING**

Many of the screws, and nuts on this product are considered to be special high-strength fasteners. They require periodic checks and maintenance to ensure the safety of both the user and attendant.

1. Most adjustments that require removing hardware should be done by your Service provider.
2. Only use fasteners provided by an authorized supplier (or ones of the same type and strength), as indicated by the markings on the heads.
3. Do not over- or under-tighten fasteners. If screws or nuts become loose, tighten them as soon as possible.

**D. ANTI-TIP TUBES****⚠ WARNING**

Anti-tip tubes can help keep your mobility device from tipping. Do not remove the anti-tip tubes and always use them in the down position whenever the base is unfolded.

**E. FOOTREST****⚠ WARNING**

1. Adjustment of the footbed may cause interference with the front lower frame in some positions. This interference can affect the comfort and proper support for the seated dependent.
2. Avoid putting extra weight on the footbed. The mobility device may tip forward (or backward if seating system has been reversed).
3. Never lift this mobility device by the footbeds.

**F. TIRES AND WHEELS****⚠ WARNING**

1. Yearly tire inspection for excessive wear is suggested to ensure good traction in all types of environments.
2. When installing front or rear wheel/tire assembly, slide the wheels into the axle opening until the quick release button pops out, and you hear a click. Your wheel is now fully engaged and locked.

**G. PARKING BRAKE****⚠ WARNING**

Never engage the parking brake to slow or stop this product when it is moving. To keep the rear wheels from rolling, always engage the parking brake fully when you transfer your dependent or the dependent seating system.

**H. UNDERCARRIAGE STORAGE****⚠ WARNING**

This mobility device's storage basket was designed for the addition of up to 15lbs of additional weight. Excessive weight may cause an unstable or hazardous condition to exist.

**I. ACCESSORY TRAYS****⚠ WARNING**

The accessory trays should not be used to store excessive weight, or a piece of equipment that has not been approved for use by Sunrise Medical. This may cause an unstable or hazardous condition for the rider or attendant.



**J. CANOPY**

**⚠ WARNING**

When using the canopy, make sure that it is secure by checking the clamps that hold it to the base.

**K. SEATING SYSTEMS**

**⚠ WARNING**

DO NOT change the seating system, or individual components of your dependent mobility device unless you have first consulted your health care professional.

**L. PELVIC POSITIONING BELTS**

**⚠ WARNING**

The positioning belt is predominately used to support your posture. It can also be used to limit slipping and/or sliding that you might experience when the chair is in motion. The positioning belt is not a transit rated safety belt and should not be used in the place of a seat belt while being transported in a motor vehicle. Improper use of Positioning belts may cause severe injury or death. If you use a positioning belt, be sure to follow the recommendations in this section:

1. Make sure the rider does not slide down in the wheelchair seat. If this occurs, the rider may suffer chest compression or suffocate due to pressure from the belts.
2. The belts must be snug, but must not be so tight that they interfere with breathing. You should be able to slide your open hand, flat, between the belt and the rider.
3. A pelvic wedge or a similar device can help keep the rider from sliding down in the seat. Consult with the rider's doctor, nurse or therapist to find out if the rider needs such a device.
4. Use positioning belts only with a rider who can cooperate. Make sure the rider can easily remove the belts in an emergency.
5. NEVER use the positioning belts:
  - As a patient restraint. A restraint requires a doctor's order.
  - On a child who is comatose, agitated or is prone to seizures.
  - As a motor vehicle restraint. In an accident or sudden stop the rider may be thrown from the chair. Wheelchair positioning belts will not prevent this, and further injury may result from the belts or straps.

*If you fail to heed these warnings, damage to your chair, a fall, tip-over or loss of control may occur and cause severe injury to the rider or others.*

**M. CUSHIONS**

**⚠ WARNING**

This mobility device's seating was designed for comfort and postural support. If seating component modifications are necessary, consult your healthcare advisor.

**N. TILT AND RECLINE**

**⚠ WARNING**

Using the tilt or recline adjustments triggers before taking the necessary precautions may effect the balance and stability of your device. BEFORE making these adjustments you must be aware of the following:

1. The child must be secure in the device.
2. You must rotate the front casters forward, and engage the parking brake.
3. ALWAYS make certain that the dependent mobility device is level and stable before adjusting the tilt and/or recline.
4. ALWAYS support the seating shell when releasing the tilt trigger.

**O. TRANSIT OPTION AND USE** 1 2 3 4

**NOTE** - The Zippie Xpress has passed transit testing and is considered to be ISO 7176-19 compliant for a dependent child weighing at least 26lbs (12kg) and up to 55lbs (25kg). In transit, the occupant must be secured within the vehicle and secured in a 3 point harness. Transit straps should be secured to the front and rear transit securement points (A).

**⚠ WARNING**

1. It is recommended that the Zippie Xpress not be used to transport occupants weighing 25lbs (11kg) or less. Rather, occupants 25lbs (11kg) or less should be transported using a suitable rearward facing infant car seat.
2. If possible and feasible, the occupant should transfer to the vehicle seat and use the OEM vehicle-installed restraints.
3. The occupant must be facing the front of the vehicle during transport.
4. Wheelchair Tiedown and Occupant Restraint Systems (WTORS) must be used.
5. A Wheelchair Tiedown that has been tested in accordance with SAE J2249 must also be used in any transit situation.
6. The Occupant must be restrained with a vehicle anchored 3-point Belt.
7. Mobility device mounted accessories, such as trays and respiratory equipment, and batteries, should be removed, and secured separately. The optional Xpress vent tray, oxygen holder, and IV pole must also be removed and secured separately before using as a seat in a motor vehicle.
8. The occupant must not weigh more than 55lbs. (25 Kg).
9. The location(s) of the front and rear securement points(A) are marked with a transit point label for clear identification.
10. Use only with WTORS that have been installed in accordance with the manufacturer's instructions and SAE J2249. Attach WTORS to the securement points(A) in accordance with the manufacture's instructions and SAE J2249.

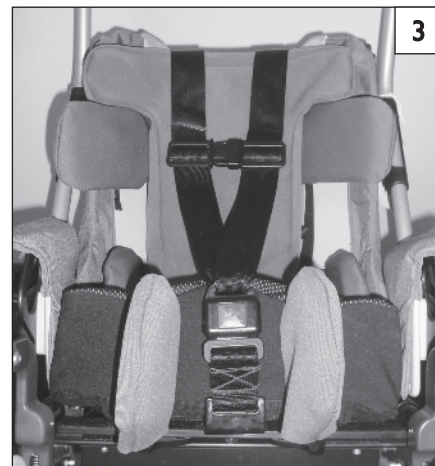
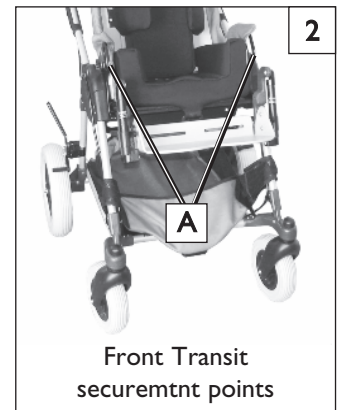
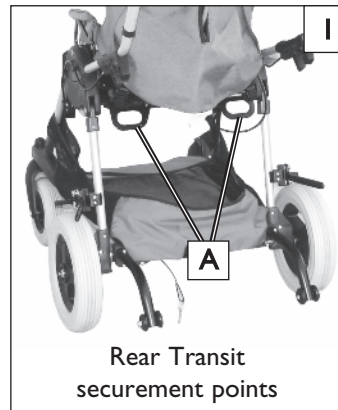

Look for this symbol on your wheelchair. It indicates wheelchair securement points which conform to ANSI/RESNA (1998) V.1 - Section 19 and/or ANSI/RESNA (2012) V.4 WC-19, and ISO 7176-19.

11. The angle of the pelvic belt should be within the preferred zone of 45 to 75 degrees to the horizontal, or within the optional zone of 30 to 45 degrees to the horizontal (Fig. 4)
12. The pelvic belt should be worn low across the front of the pelvis. Position upper torso belts over the shoulders. The belt(s) should not be held away from the body by wheelchair components. Ensure that the belts are not twisted.
14. If a recline angle is required during transport, the chair seat/back should be positioned at an angle of no more than 30° to the vertical, or the occupant is at risk of injury in the event of an accident or collision.
15. Attach all occupant restraints in accordance with the manufacturer's instructions and SAE J2249.

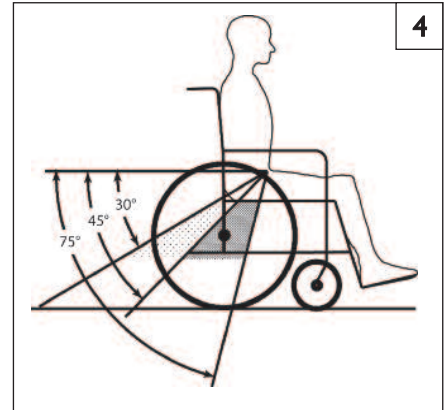

**NOTE-** To obtain a copy of SAE J2249 "Wheelchair Tiedown and Occupant Restraint Systems for Use in Motor Vehicles" Please contact:  
 SAE International, 400 Commonwealth Drive  
 Warrendale, PA 15096-0001  
 or by phone at (724)-776-4970, or (877) 606-7232

P. TRANSIT CONFIGURATIONS

5 6

**⚠ WARNING**

Be sure the device is in one of the configurations below if the occupant must be transported in a motor vehicle and secured with (WTORS) and the requirements of SAE J3349.

1. For Children over 20lbs, the positioning shell/mobility base unit has been dynamically tested with the occupant facing forward for a 30 mph (48-km/h) frontal impact test. The occupant must be facing the front of the vehicle during transport, (See Fig. 5)
2. For children 20lbs and under that cannot be transported in an approved car seat, the positioning shell/mobility base unit has been dynamically tested with the occupant facing rearward for a 30mph (48-km/h) frontal impact test. The occupant must be facing the rear of the vehicle during transport, (See Fig. 6)

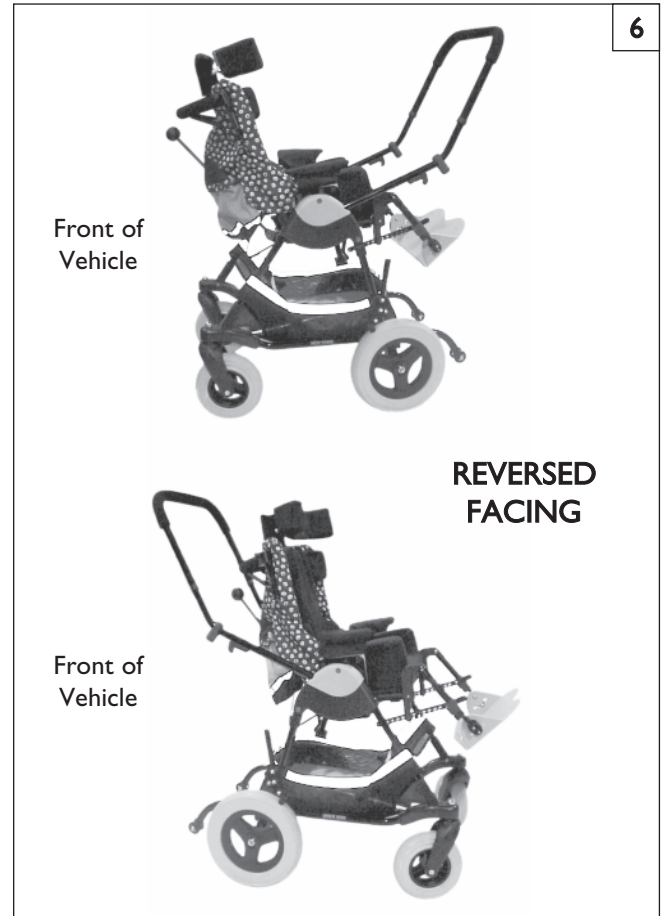
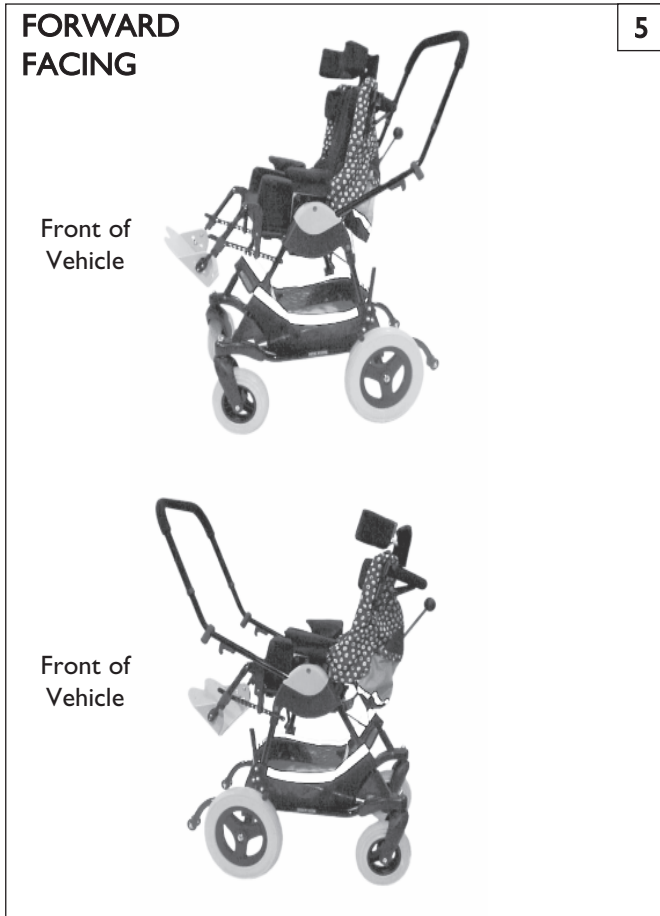

**A. MAINTENANCE AND SAFETY NOTES**

1. Proper maintenance will improve performance and extend the useful life of your mobility device.
2. Clean the device regularly. This will help you find loose or worn parts and will make your device easier to use.
3. To protect your investment, have all major service and repair work done by your supplier.
4. At least every four months, check all screws and knobs for tightness. If parts are missing, broken, damaged or worn, then discontinue use of the product until repairs are made, using factory-authorized parts.
5. Wipe down all plastic components periodically with a solution of mild soapy water to maintain cleanliness.
6. Hand wash and air-dry the fabric components as needed.
7. Lubricate all moving metal parts with a teflon lubricant only.

**NOTE** - Using lubricant other than Teflon-based may damage moving parts

8. Check the parking brake lock pin weekly to make sure it engages smoothly into the wheel hub. This simple check will insure the safety of the rider. Lubricate with a Teflon Lubricant when needed.
9. Check and clean the wheel attachment points frequently, this is a main area that can collect dirt and grime. Debris in this area can effect the performance and safety of the device.

**⚠ WARNING**

1. **Your device needs regular maintenance for peak performance and to avoid injury from a device failure, damage or premature wear.**
2. **Inspect and maintain this device strictly using this Owner's manual as a reference.**
3. **If you detect a problem, make sure to service or repair the device before putting it back into use.**
4. **At least once a year, have a complete safety check and service of your device performed by your supplier.**

**B. CLEANING**

**Base Frame Parts:**

- Clean with mild soapy water monthly.

**Upholstery:**

- Hand-wash as needed. Machine wash as needed.
- Drip-dry only. Heat from a dryer may damage fabric.

**NOTE** - Washing the fabric may decrease fire retardant properties.

**C. STORAGE TIPS**

1. Store your device in a clean, dry area. If you fail to do so, parts may rust or corrode.
2. Before using your mobility device, make sure it is in proper working order. Inspect and service all items included in this Manual.
3. If you store this device for more than three months, have it inspected by a supplier before use.

**D. SAFETY CHECKLIST**

Weekly	3 Months	6 Months	Annually	Safety & Function Check
<input checked="" type="checkbox"/>				Tire inspection (excessive wear,cracks)
<input checked="" type="checkbox"/>				Parking brake holds firm (no slipping)
	<input checked="" type="checkbox"/>			Visually check for loose hardware
		<input checked="" type="checkbox"/>		Securement and positioning belts
		<input checked="" type="checkbox"/>		Axle and axle sleeves (check for debris)
	<input checked="" type="checkbox"/>			Quick-release axles (Remove clean)
<input checked="" type="checkbox"/>				Caster tires: (Excessive wear, cracks)
	<input checked="" type="checkbox"/>			Casters: (level, and move smoothly)
	<input checked="" type="checkbox"/>			Seating interface: (check for debris)
		<input checked="" type="checkbox"/>		Frame, Folding Mechanism
		<input checked="" type="checkbox"/>		Upholstery: (clean and dry)
			<input checked="" type="checkbox"/>	<b>Service by Authorized Dealer</b>

**NOTE** - The user or caregiver should perform these weekly and monthly checks to maintain the safety of their chair. If an item is not working properly, please contact your authorized dealer.

**E. REAR WHEEL REMOVAL AND INSTALLATION** 7

Remove the Rear wheels to reduce the mobility base storage size.

- a. To remove, depress the axle release button (A) in the center of the rear wheel and pull the whole wheel and axle out of the axle tube.
- b. To Reinstall, align the axle with the axle tube end and depress the button while pushing the axle and wheel assembly inward until it stops. The axle is locked when the release button pops out, and the axle is effectively locked in place.

**⚠ WARNING**

Pull on the wheel assembly to verify that it is locked in place. Occasionally, the wheels do not both snap into place. If this should happen, then swap the wheels to the opposite sides.

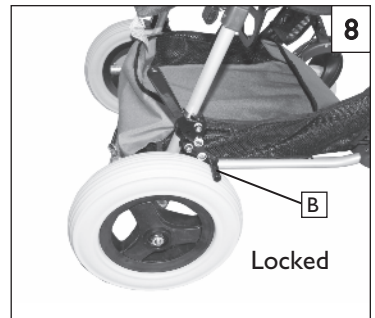
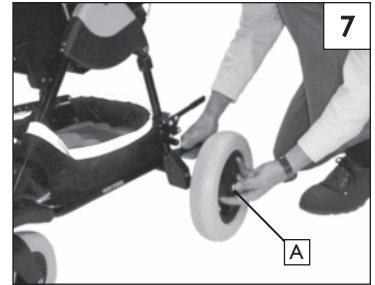

**F. WHEEL LOCKS** 8 9

Locking and unlocking the wheel locks

- a. To lock the wheel lock, Pull on the black handle (C) until the locking arm (B) is embedded into the tire about 1/8" and check to insure that the lock has been engaged and the handle is locked in place.
- b. To unlock the wheel lock, press down on the black handle (C) until the locking arm is disengaged from the rear tire.

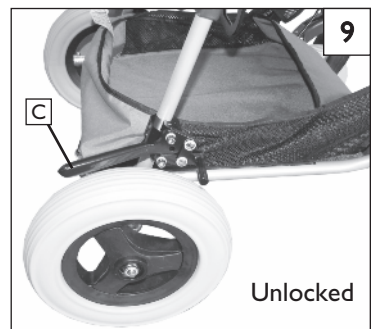

**G. UNFOLD AND FOLD** 10 11 12 13

**⚠ WARNING**

Zippie dependent mobility devices are designed for stability and performance. When unfolded, the device must be fully open and locked to avoid injury to the dependent rider. Follow the instructions for unfolding the device carefully, and double-check that the device is fully locked and the fold lock-out pin is installed before adding the seating shell and rider.

Unfolding:

- a. Unhook the fold retaining strap and store in the tray provided under the seating shell.
- b. Insert or rotate the anti-tips (D) into a downward position
- c. Place the mobility base on the floor with wheel locks engaged. make sure that the mobility base fold lock out pin (E) is not inserted into the lock out hole.
- d. Lift the handle bar into the locked position, then lift up so that the frame unfolds and locks into the upright position.
- e. Insert the mobility base lock pin (E) into the lockout hole. When inserted into the hole, the locking pin prevents the rear wheels and axle from folding under the mobility device.
- f. If the shell is being installed separately, see the positioning shell installation instructions, in order to position the shell back, depress the recline lever and pull back. Adjust the legrest, tilt and optional recline to the appropriate configuration.

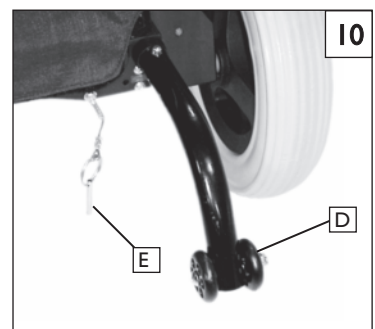

**Two-stage Folding Frame**

**I. Rotating the handle into storage position:** 14 15

**⚠ WARNING**

The Xpress is not intended to be folded with the seating and/or accessories installed. ALWAYS remove the child and any extra items prior to any action required to fold the base. Failure to do this may damage the product, or cause possible injury to the child, and/or attendant.

- a. Engage the wheel locks, and remove the child from the device.
- b. You may also choose to remove the seating shell at this stage.
- c. Activate the trigger handle (B) (Fig.15) and fold the handle (A) downwards until it is fully lowered against the frame as shown in (Fig. 14).

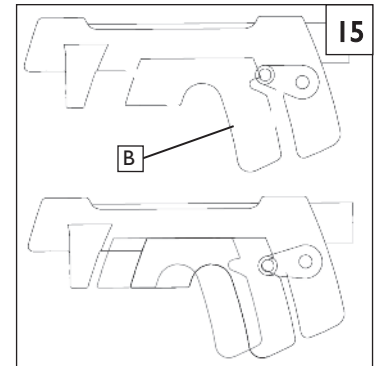
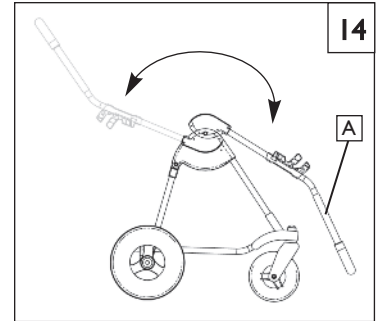

**Two-stage Folding Frame**

**I. Full compact folding:** 16 17 18

The Xpress can fold compactly with the shell installed in the forward facing position.

- a. Engage the wheel locks, and remove the child from the device.
- b. You may also choose to remove the seating shell at this stage.
- c. Elevate the legrests, and tilt the seat to the most forward position.
- d. Remove the fold lockout pin (C)
- e. Activate the trigger handle (B) and fold the base as shown in (Fig. 17).
- f. See (Fig. 18) for frame in fully compact folded position.

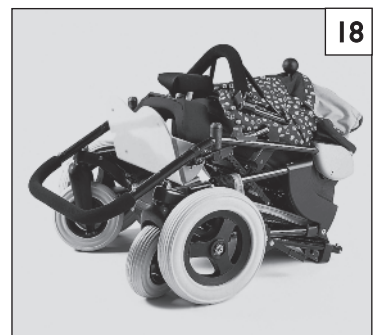
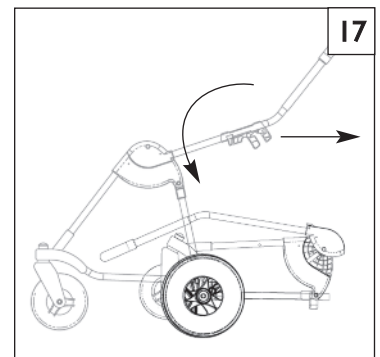
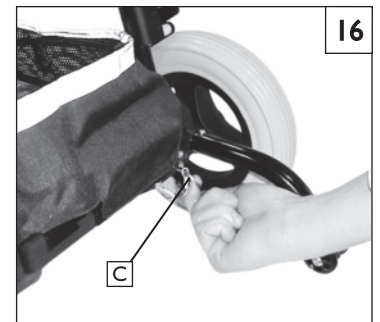

## H. POSITIONING SHELL INSTALLATION 19 20

### WARNING

BEFORE installing the seating shell, always check that the mobility device is completely unfolded and in the locked position, and that all four wheels are locked in place. The seating shell should never be installed with a seated occupant. Always remember to stabilize the mobility device before performing this action.

- Rotate the front casters until they point forward.
- Engage the wheel lock.

The positioning shell has a pivot post on each side that mounts the shell to the mobility base. The mobility base has a slot on each side that receives the shell pivot posts. The shell will not install onto, nor remove from, the mobility base when the base push handle is folded. The positioning shell may be installed in a child facing forward or rearward position. Installation is the same either direction.

#### Installation in the forward or reversed direction

- Place the shell over the top of the mobility base, and squeeze the tilt-in-space (TIS) lever (D) attached to the right side of the shell handle.
- Align the tilt-in-space guide pins (A) and pivot posts (B) with the mobility base pivot slots (C) and lower the shell into place.
- Adjust the legrest, tilt, and optional recline to appropriate configuration.

## I. POSITIONING SHELL REMOVAL 21 22

### WARNING

BEFORE removing the seating shell, always remove the occupant to a safe location. Failure to do so may result in injury to the dependent, and/or caregiver. Always remember to stabilize the mobility device before performing this action.

- Rotate the front casters until they point forward.
- Engage the parking brake.

#### After removing the occupant:

- Make sure the seat is in the fully upright position (no recline or tilt), and that the push handle is in its normal use position before you remove the shell.
- Squeeze and hold the TIS lever (D).
- Lift the shell vertically from the mobility base.

Forward position

19



Reversed position

20



21

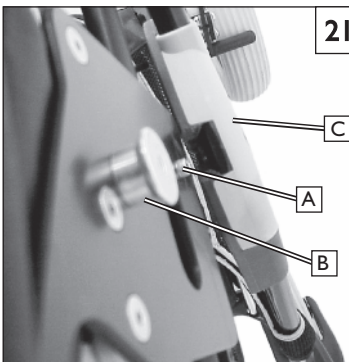

22

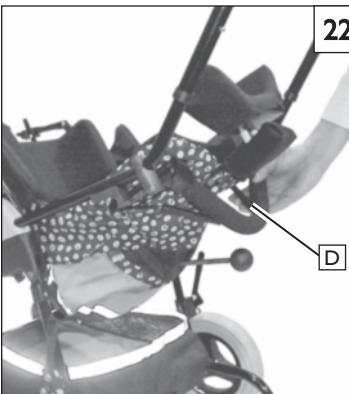

**J. TILT IN SPACE ANGLE ADJUSTMENT** 23**⚠ WARNING**

BEFORE using the tilt adjustment, always check that the mobility device is completely unfolded and in the locked position, and that all four wheels are locked in place. Be careful to avoid pulling or crimping any life support tubing that may be attached to the child. Always remember to stabilize the mobility device before performing this action.

- Rotate the front casters until they point forward.
- Engage the wheel locks.

**Tilt adjustment**

- Move to the rear of the device behind the child.
- Support the seating shell with both hands and squeeze the tilt-in-space lever (A). Position the shell to the desired tilt angle adjustment. The back support, and seating support components, including the footrest should move together.
- Release the handle and gently pull on the seating shell to make sure it is locked in the new position.
- This adjustment can change the balance of the device slightly so it is good to check that there is no danger of tipping with the new setting.

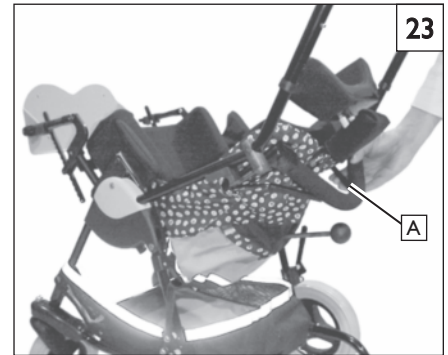
**K. HIP ANGLE ADJUSTMENT (No recline option)**

**NOTE** - One or more adjustment limiting collars may be attached to the seating system to reduce the range of available hip angles. they attach to the mechanical lock shaft. Consult your supplier and therapist for adjustment needs.

**Adjustment to recline the back and adjust hip angle.**

- Remove the child from the device for this adjustment.
- Adjust the hip angle by removing the screw that attaches the frame tube to the back-shell bracket.
- Position the back to the desired angle, re-insert the screw and tighten.
- The lower mounting point of the back is provided with a quick release pin to facilitate folding of the back.

**⚠ WARNING**

Be sure that the attachment screw, and quick-release pin are installed and the back is secure before using the device.

**L. RECLINE ADJUSTMENT (Optional)** 24**⚠ WARNING**

BEFORE using the recline adjustment, always check that the mobility device is completely unfolded and in the locked position, and that wheel locks are locked in place. Be careful to avoid pulling or crimping any life support tubing that may be attached to the child. Always remember to stabilize the mobility device before performing this action.

- Rotate the front casters until they point forward.
- Engage the wheel locks.
- If equipped with shoulder harness, loosen the shoulder straps to allow room for the recline.

**Recline adjustment**

- Working from the left side of the occupant, grasp the recline adjustment lever (B) while supporting the shell with your other hand.
- Squeeze the lever then pull on the back support area. When desired angle adjustment has been reached, release the handle and gently pull on the seating shell to make sure it is locked in the new position.
- This adjustment can change the balance of the device slightly so it is good to check that there is no danger of tipping with the new setting.
- If equipped with shoulder harness, re-adjust the straps for proper fit.

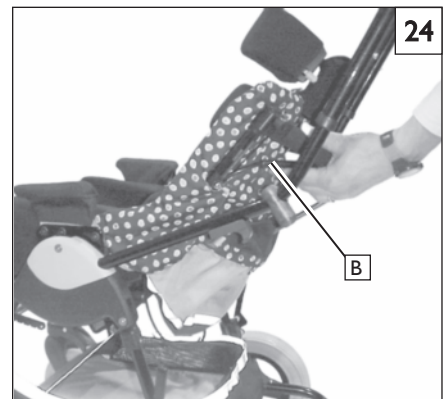

**M. KNEE ANGLE ADJUSTMENT** 25**⚠ WARNING**

Always stabilize the mobility device before performing this action.

- Rotate the front casters until they point forward.
- Engage the parking brake.

The knee angle adjustment can be done with occupant in the device.

- a. Be careful to avoid pulling or crimping any life support tubing that may be attached to the child. This adjustment can create a pinch point, so be careful to remove any obstruction, and/or clothing that could get stuck in this area.
- b. Press down on the thumb activated levers (A) at each side of the footbed/hanger. and adjust the Knee angle to the desired angle.

**NOTE** - The levers may not move easily until you have adequately supported the weight of the occupant's legs.

- c. Release the levers and allow the Knee angle to lock into place as you remove the support from the footbed/hanger.
- d. Make sure the levers are properly locked after every adjustment.

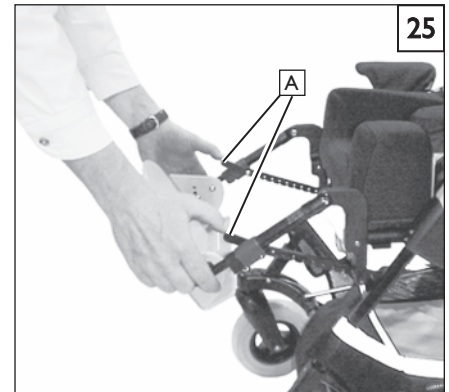
**N. CANOPY INSTALLATION AND ADJUSTMENT****⚠ WARNING**

It is always best to make sure the dependent is not seated in the mobility device during the installation of accessories.

**Canopy installation** 26 27

- a. Loosen the two thumbscrews (B) located near the top of the back. They screw into black couplers on each side.
- b. Put the canopy rod ends into the mounting holes, raise or lower the canopy to the proper height and tighten the thumbscrews.

**Canopy adjustment** 27

- a. Once installed, you can adjust the canopy angle by pushing it forward or backward until desired protection is obtained.
- b. Lift the front of the canopy all the way up for clearance and access to the child.
- c. When canopy is being used with the tilt and recline adjustments, it may be necessary to angle the canopy either forward or rearward for better clearance with the push handle.

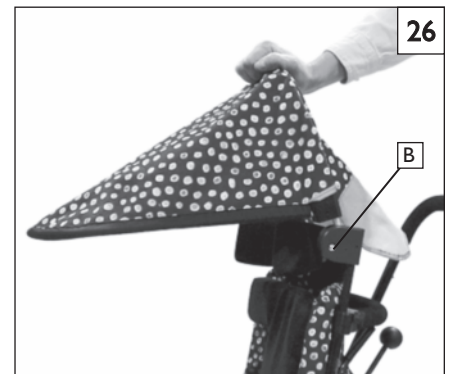





## A. POSITIONING AND GROWTH ADJUSTMENTS

### ⚠ WARNING

If a change in adjustment is necessary for growth or positioning, a healthcare professional must be consulted before any changes are made. These adjustments are very important to the orthopedic and neurological needs of the child. Care should be taken to make sure the changes are physiologically and medically appropriate. Sunrise Medical suggests that any positioning or growth adjustments be made by your service provider. Do not make or allow any of the following adjustments while the child is seated in the mobility device.

### TOOLS YOU WILL NEED

To set-up, adjust and maintain your device you will need the following tools:

1. 4mm hex key for some growth adjustments.
2. 5/32 hex key (for headrest collar adjustments)
3. 10mm open end wrench
4. Torque Wrench

If you plan to adjust and maintain this device yourself, Sunrise recommends that you use a torque wrench.

**NOTE** - The torque wrench must measure inch-pounds. You may buy a torque wrench and proper metric sockets from any local hardware store.

In general, positioning and growth adjustments should be done in the following order:

1. Adjust seated area
2. Adjust back support area
3. Adjust pelvic positioning belt
4. Adjust footbed
5. Adjust head support(s)
6. Make other standard and optional adjustments that are needed
7. Check to be sure that all adjustment screws are torqued to specifications

## B. SEAT DEPTH ADJUSTMENT 30

- a. Start by determining the proper seat cushion depth.
- b. Remove the seat cushion. It is attached with Velcro®.
- c. Loosen the seat depth adjustment screws (A) found on each side of the frame from under the seat base (do not remove).
- d. Adjust the depth by sliding the front of the seat pan forward, or backwards.
- e. Re-tighten hardware(A) and re-attach the cushion.

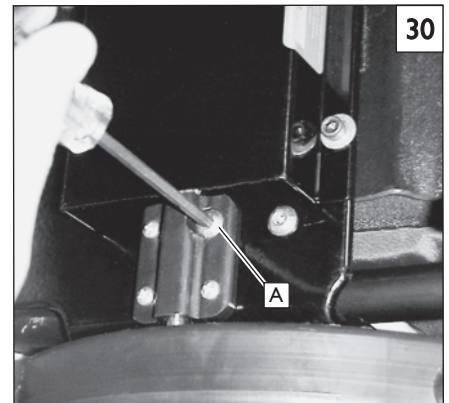

## C. STANDARD SEAT CUSHION ADJUSTMENT 31

The standard seat cushion comes in two seat lengths, short and long. The short seat is 7" long with capability for adding a 2" growth strip at the back of the cushion. The long seat is 9" long with capability for adding a 2" growth strip at the back of the cushion. Both are capable of adjustment from 5.5 to 11.5 inches width adjustment by adding or removing adductor foam pads.

### Adjusting the width.

- a. Unzip and remove seat cover. Add or remove the same combination of adductor foam pads to each side of the seat, to achieve the desired width.
- b. Re-install the cover over the seat and close the zipper.

### Adding growth strip:

- a. Unzip seat cover to expose the back edge of the foam cushion.
- b. Lift the foam overlay pad at the back of the seat and install the growth strip with tapered ends down.
- c. Place the overlay evenly over the growth strip and close the zipper around the growth strip.

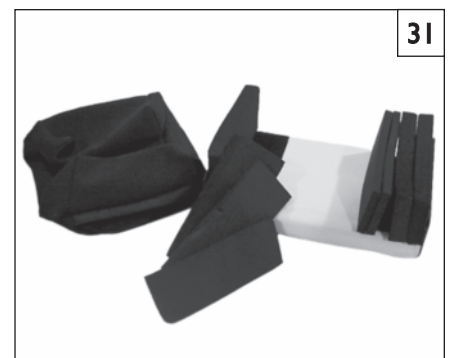

**D. CONTOURED SEATING CUSHION ADJUSTMENTS** 32 33

The contoured seat cushion comes in two lengths: short and long. The short cushion is 7" long with capability to add either a 1 1/2" or 3" growth strip making the length 8 1/2" or 10" respectively. The long cushion is 8" long with capability to add either a 1 1/2" or 3" growth strip making the length 9 1/2" or 11" respectively. These growth strips are added at the center of the seat cushion.

**Adding growth strips**

- a. Unzip seat cover and fold the top over the front edge to expose the cushion.
- b. Lift the foam overlay piece away from the velcro attachment, using care not to tear the foam.
- c. Grasp the rear foam section at the middle and lift it from the velcro attachment.
- d. Add the either the 1 1/2" or the 3" growth strip at the back of the front foam section assuring that the angled edges and sides align.

**Note:** Never use both growth strips at the same time.

- e. Re-attach the rear section assuring the angled edges and sides align.
- f. Adjust the adductor wedges as needed and position the foam overlay over the cushion and attach to the velcro at the rear of the seat.
- g. Close the zipper around the cushion and install into the unit.

**Cleaning the seat cover**

- a. Unzip the cover along the edge.
- b. Remove the cushion assembly from the velcro attachment inside the cover.
- c. The fabric seat cover should be hand washed in laundry soap, thoroughly rinsed with clean water and air dried.
- d. The foam cushion pieces may be wiped down with soap and water. Always be sure they are completely dry before replacing the fabric cover.
- e. Place the cushion into the fabric cover onto the velcro with the front edge of the cushion aligned with the front edge of the cover.
- f. Pull the cover over the cushion and close the zipper around the cover.

**E. STANDARD CUSHION WITHOUT LATERAL HIP SUPPORT**

The standard Cushion without-Lateral Hip Supports comes in two seat lengths, short and long. The short seat is 7" long with capability for adding a 2" growth strip at the back of the cushion. The long seat is 9" long with capability for adding a 2" growth strip at the back of the cushion.

**F. BACK POSITIONING PLATE HEIGHT ADJUSTMENT** 34**Adjusting the back positioning plate**

- a. Open the exterior back panel fabric sections on the outside to expose the back growth slots and adjustment screws.
- b. Loosen the screws through the access holes (A) behind the back plate on each side, adjust to proper height.
- c. Tighten both adjustment screws and make sure the back plate is locked in position.

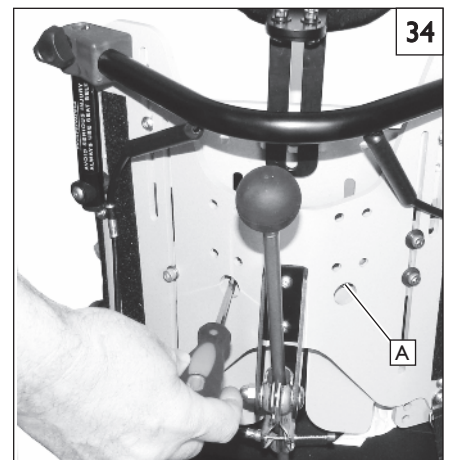
**G. BACK CUSHION HEIGHT ADJUSTMENT**

- a. Fit the back cushion to the positioning plate at proper height.
- b. Add appropriate back cushion growth inserts if a gap is present at the bottom of the back cushion.

## H. FOOTBED ADJUSTMENTS 35 36

### Height Adjustment

Two telescoping tube sections adjust and lock to control footbed height.

- Identify adjustment screw locations on the rear side of the footbed hanger.
- Loosen upper screw on each side of the footbed hanger.
- Slide the footbed up or down to proper height.
- Tighten both screws.
- Repeat procedure using lower screw in step 2 if additional range is required.

### Angle Adjustment

The footbed has two screws that fit into a series of holes in the footbed sides and two more that allow footbed rotation.

- Remove the footbed angle adjustment screw on each side of the footbed.
- Adjust the footbed to proper angle and align nearest adjustment holes with the footbed couplers.
- Install adjustment screws through footbed and into footbed coupler to maintain proper footbed angle.

### Lengthening the Footbed for Maximum Lower Leg Length Adjustment

The foot bed is designed so that the brackets on the ends of the telescoping tubes can be reversed to add approximately 3 1/2" of leg length adjustment.

- Remove the footbed from the telescoping tubes by unscrewing the four button head screws (A) on the inside of the footbed.
- Remove the screw from each bracket by backing it out far enough to allow the bracket to slip off the end of the tube.
- Flip the bracket over and replace it on the end of the tube being careful to align the screw with the same hole in the end of the tube.
- Tighten the mounting screw so it goes through the hole and tightens up against the bracket.
- Replace the footbed onto the brackets assuring the same angle adjustment is achieved.

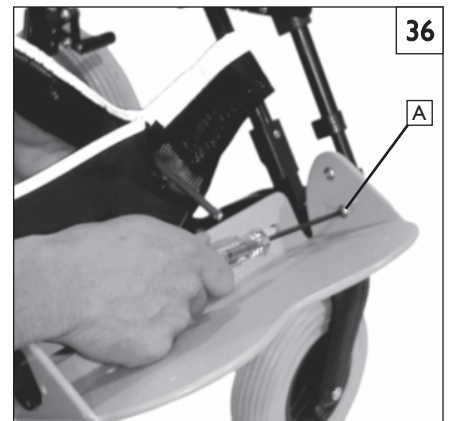

## I. PELVIC POSITIONING BELT ADJUSTMENTS 37 38

### Length Adjustment

- Remove any belt twists and place the belts outside of the seating area.
- Engage wheel locks, seat the child, and snap the pelvic positioning belt ends together.
- Adjust belt length to provide a snug fit. The adjuster is to the child's left.

### Position Adjustment

For the standard seat configuration the belt is always adjusted to the rear most point (approximately 45°). When the contour seat cushion is used, the belt may be adjusted forward to achieve an adjustment of up to 90°.

- Loosen the attachment screw (B) one or two turns to allow the belt anchor point to slide in the slot.
- Move the belt to the desired adjustment position (leave in the rear most position when the standard seat configuration is used).
- Tighten the screw.

**NOTE** - Install the nylon web strap wraps under the tube, beside the seat base, and back over the top of the tube. This keeps the belt in the outer most position so it does not interfere with the seat cushion.

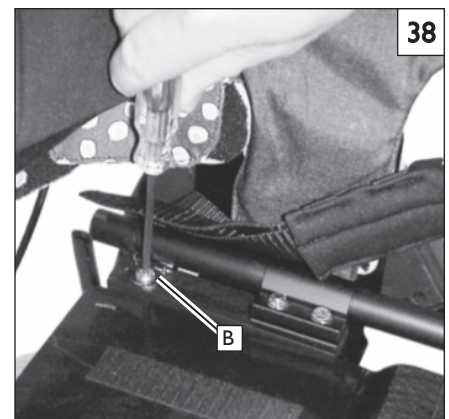
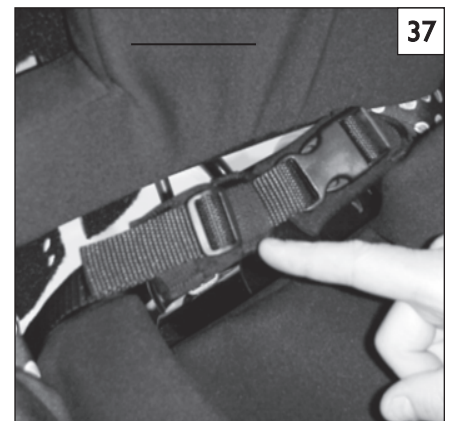

J. ANTERIOR TRUNK BUTTERFLY SUPPORT 39 40

**⚠ WARNING**

To avoid serious injury or issues with eating or breathing, the pelvic positioning belt is required to be used in combination with the butterfly harness. Double-check all adjustments to ensure there is no possibility of obstructing the airway or any other undesired constrictions. Do not use the butterfly harness without the pelvic positioning belt.

**3-point Harness Adjustment**

- a. Place the child in the seating system and fasten the pelvic positioning belt.
- b. Position the child's hips and tighten the belt to the proper position.
- c. Connect the butterfly harness (two styles) to the straps already fastened to the positioning shell.
- d. First, adjust the lower butterfly straps to keep the butterfly from riding up on the child's torso.
- e. Then, adjust the upper straps making sure there is enough room around the child's neck for easy breathing and eating.
- f. Once the butterfly straps are adjusted, snap the lower straps into the plastic tri-glide up against the quick release buckle.

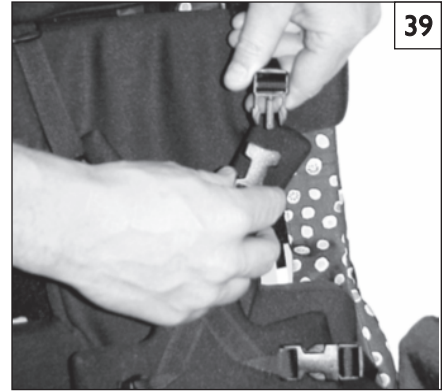

K. LATERAL TRUNK SUPPORTS (Optional) 41

**Assembly to the Seating Shell**

- a. From behind your unit, pull back upholstery and remove the back pad to expose the plastic back shell.
- b. Insert screws and washers (A) from the rear of the shell through the adjustment slots.
- c. Thread the bolts into the lateral nut plate (B) clamping the lateral mounting plate to the backshell.
- d. Seat the child and properly adjust the laterals for support and comfort.
- e. Tighten the screws.

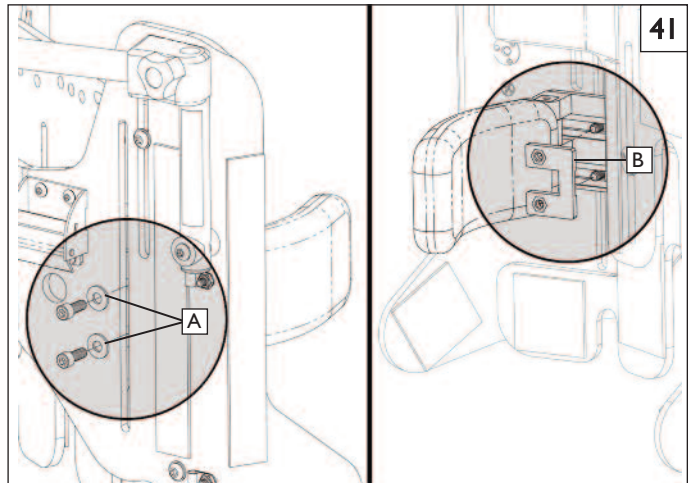

**Lateral Swing-Away Operation** 42

- a. Depress the silver lever (C) allowing the lateral to swing inwards or outwards. This is useful for storage or helping a child into or out of the seating system.

**NOTE** - The laterals lock into the adjusted preset position which can be angle adjusted by following steps in the next section "Lateral Angle Adjustment".

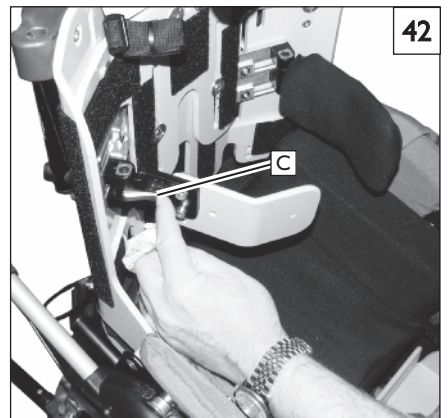

**Lateral Height and Width Adjustments**

43

**NOTE** - The following adjustments can be done with the child present in the seating system.

- a. Unzip the rear cover to access the adjustment screws.
- b. **Loosen** (do not remove) the mounting screws (A) from the front of the shell enough to gain horizontal adjustment of the laterals. Adjust the lateral brackets for width bringing the lateral assembly including the pads to the proper position. If more horizontal adjustment is needed, you can also adjust the swing-away bracket.
- c. Tighten the mounting screws to hold the adjustment.
- d. To gain vertical adjustment of the laterals, loosen screws (A) from the rear of the back-shell, and move the laterals up or down to the proper position, and tighten the screws.

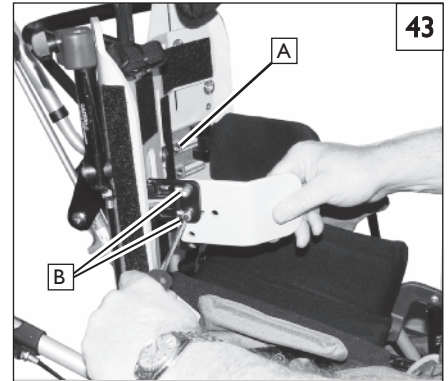

**Lateral Length and Rotation Adjustments**

43

- a. Slide the lateral cover and foam forward or remove to expose adjustment screws.
- b. Loosen screws (B) and move lateral to proper length, you can also add a slight rotation by twisting the lateral slightly. Be sure to make the same adjustment on the other side.
- c. Tighten screws and replace the foam and cover.

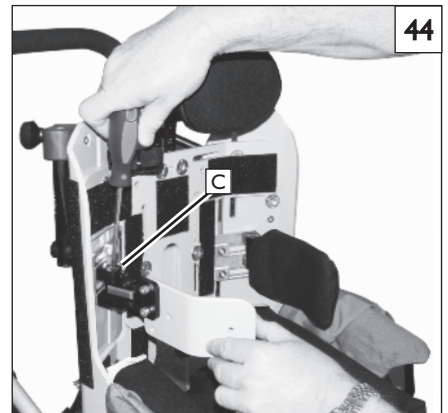

**Lateral Angle Adjustment**

44

- a. Lock the lateral by rotating inwards.
- b. Loosen the angle lock screw (C) as shown at the lateral hinge point.
- c. Adjust the lateral angle to the proper position and tighten.

**L. HIP PADS**

45

**Width Adjustment**

- a. Determine the proper location for each hip pad.
- b. Remove the seat cushion to expose hip pad adjustment screws(D).
- c. Loosen two adjustment screws for each hip pad.
- d. Adjust hip pads to the desired position.
- e. Tighten the adjustment screws and replace the seat cushion.

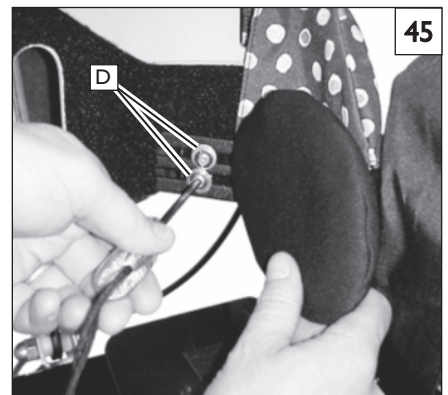

**Forward /rear Adjustment**

- a. Determine the proper location for each hip pad.
- b. Remove the foam cover from the hip guide to expose hip pad adjustment screws.
- c. Loosen two adjustment screws.
- d. Adjust hip pads to the desired position.
- e. Tighten the adjustment screws and replace the seat cushion.

**M. KNEE ADDUCTORS**

46

**Angle and Width Adjustment**

- a. Locate adjustment screw. (E) Screw is located beneath the forward edge of the seat. Seat cushion removal aids greatly in finding screw location.
- b. Lock the wheels, seat the child, and buckle the pelvic positioning belt.
- c. Loosen the adjustment screw from beneath the seat and adjust medial pad to proper width and angle.
- d. Tighten adjustment screw to lock the pad in position.
- e. If using 2 pads, repeat the adjustment sequence on opposite side.

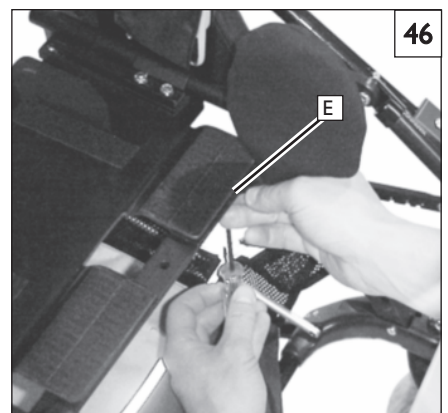

**N. ABDUCTOR PAD** 47

Abductor pads are optional equipment.

**Abductor pad installation**

- a. Raise the footrest up so that it is horizontal with the seat pan.
- b. Find the two holes in the seat pan, located on both sides of the footrest tube.
- c. Seat cushion must be attached.
- d. Slide the metal bracket through the slot in the cushion and align holes in the bracket with the holes in the seat pan.
- e. Attach the abductor pad(A) to the seat pan with hardware(B).

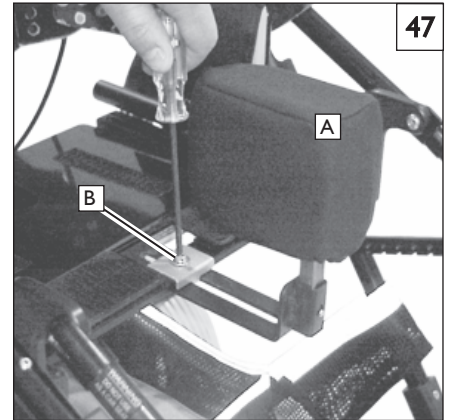

**O. ANTERIOR SUPPORTS** 48 49 50

When deciding if you should use Anterior supports, always consult your healthcare advisor.

Some children, due to their disability level or physical condition, may need anterior supports to help maintain proper posture or body position. Such devices include head straps, shoulder straps, thoracic strap systems, pelvic supports, and belts.

**⚠ WARNING**

**Risks of injury with head supports and how to avoid them.**

Excess movement or migration of the pelvis- This may cause the supports to displace. If this occurs, severe injury to the child could result.

**To avoid risks:**

1. It is VITAL to keep the child in a stable pelvic position.
2. Anterior supports should ONLY be used with seat, back, and pelvic supports or belts that keep the child from sliding down in the seat.
3. Anterior supports must be fitted by your authorized supplier and your healthcare professional.
4. After fitting, anterior supports, they should ONLY be placed and adjusted by trained professionals.
5. DO NOT leave the child unattended when using anterior supports.

**Attaching head support mount**

- a. Remove back cushion and unsnap rear shell upholstery exposing two head support mounting holes at center back of inner seating shell.
- b. Insert t-nut (C) from inside of shell attaching headrest mount with supplied screws.
- c. Tighten the hardware securely.

**Attaching head support**

- a. Align the slot in head support vertical bar with the attached mount and assemble with the height adjustment bolt (D) and washer.

**Head support adjustment (Whitmyer light-weight head support).**

- a. You can adjust height of the headrest with the height adjustment screw (E).
- b. You can adjust anterior/posterior and horizontal angle adjustment. by loosening the adjustment screws (F).
- c. You can adjust the pad tilt and angle by adjusting the collar, and collar bolts (G).

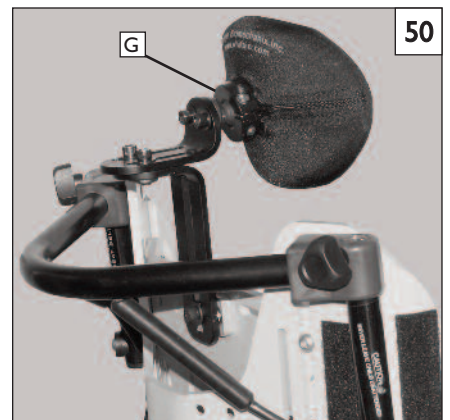
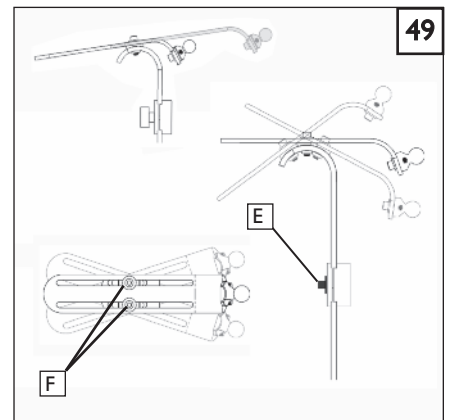
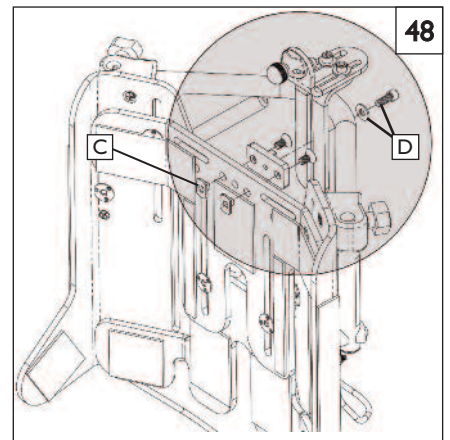

**Attaching Headrest Pad** 51

- a. Remove vinyl collar cover and insert over the knurled headrest ball.
- b. Loosen collar screws (A) enough to slip collar onto knurled ball.
- c. Be sure to evenly tighten the collar by first loosely starting the screws.
- d. Using the 5/32" hex key, tighten the screws 1/2 turn alternating between the two sides until there is an even gap as shown (Correct alignment). Make sure collar alignment is even and secure. If the collar is unevenly tightened as shown (Incorrect alignment), injury to the child could result

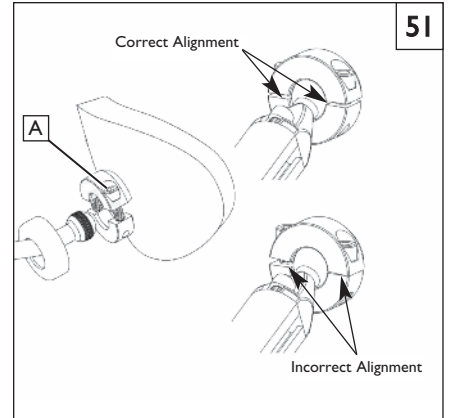

**P. HEAD SUPPORTS (Option)** 52 53

**Installation**

- a. Using a hex key Loosen the rear occipital screwball (B), adjust up or down to provide slot access.
- b. Remove the bolt and washer (C) from the mounting plate.
- c. Fit the mounting plate to the front of the occipital mount slot as shown. Plate can be mounted above or below occipital pad.
- d. Replace the bolt and washer and tighten.

**Forehead strap adjustment**

- a. Using an Allen wrench: Loosen the guide rods adjustment screw (D), and slide both guide rods evenly to desired diameter.
- b. Locate neoprene strap (E) in desired position on forehead.
- c. Slide guide rods through clamp until front of neoprene strap is approximately 1/2" from plastic guide support (F). Strap must fit snugly on forehead. (G).
- d. Re-Tighten guide rod adjustment screw to hold position.
- e. Guide rods may be trimmed to 1" limiting rearward protrusion. Vinyl caps should be removed prior to trimming and then reinstalled. (H)
- f. Re-adjust forehead strap as necessary.



**Downward stop angle adjustment:**

- a. Using an Allen wrench loosen the angle adjustment clamp screws (I).
- b. Insert an Allen wrench into the exposed hole (J) on the silver angle adjustment pivot and rotate until the forehead pad and guide rods are at the desired angle.
- c. Re-tighten the angle adjustment clamp screws and check all settings.

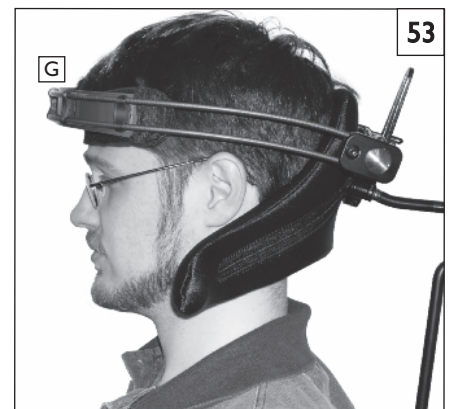

**Notice:** Fasteners and Headstrap adjustment should be checked prior to each use. Neoprene Strap must be replaced at the first signs of wear or loss of tension.

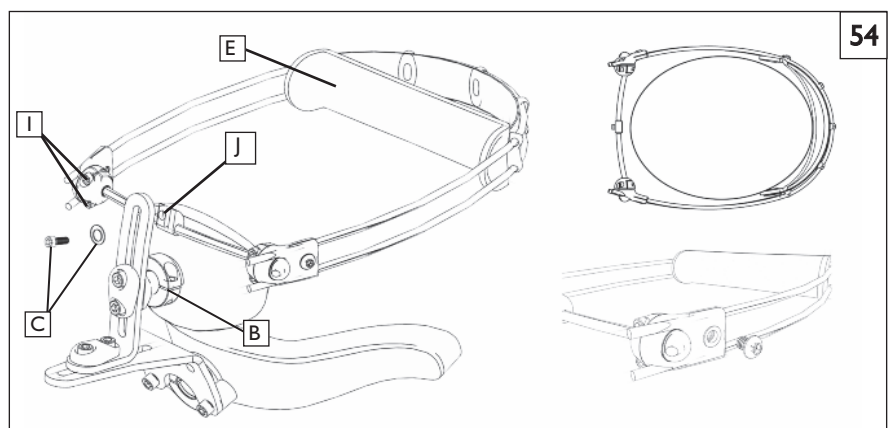



**Q. TRAY ARM HEIGHT ADJUSTMENT** 55

- a. Loosen or remove the two button head screws (A) to raise or lower the tray support arm receiver bracket (B).
- b. Adjust tray support to proper position and tighten screws.
- d. Repeat the procedure for opposite side making sure tray supports are equal in height adjustment so that the tray can be installed easily.

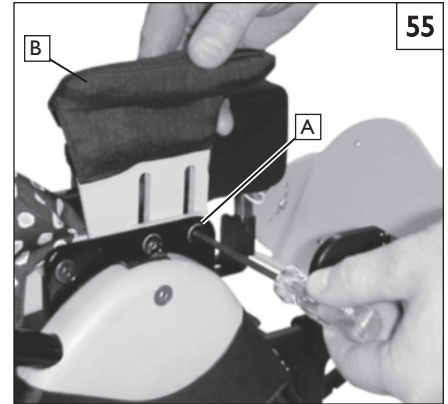

**R. TRAY INSTALLATION AND ADJUSTMENT** 56

- a. Slide the tray over the tray supports, adjust depth and clamp into place.
- b. Adjust tray supports to get proper tray height and angle.

**Note:** The tray will not work if tray support heights and angles are too different from one another. Try loosening both tray supports if tray will not align properly.

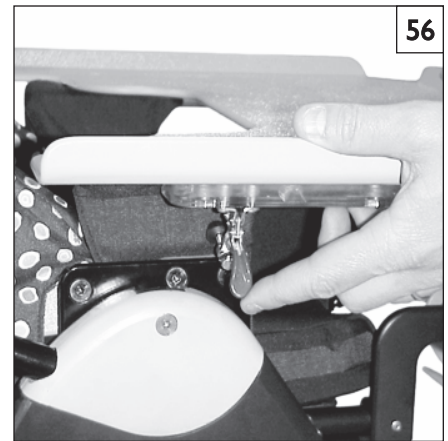

**S. SHOE HOLDER FOOT STRAP ADJUSTMENT (Option)** 57 58

**⚠ WARNING**

Using a pelvic positioning belt is critical for child safety when foot straps or shoe holders must be used for therapeutic positioning needs.

**NOTE** - Shoe holders and optional foot straps are intended for therapeutic positioning needs only.

- a. Engage the wheel locks and seat the child.
- b. Loosen the shoe holder straps
- c. Child should be wearing shoes for this step. Place child's foot into shoe holder and snap the two shoe holder straps into place.
- d. Keep the straps as loose as possible and only tighten enough to maintain a therapeutic position.

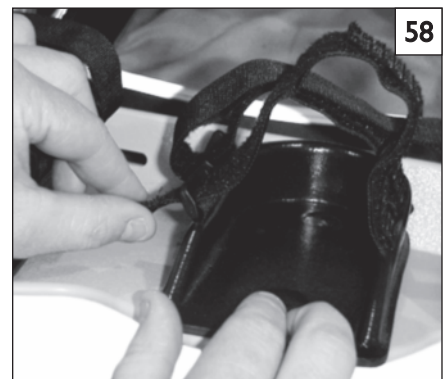



**A. FOR FIVE (5) YEARS**

Sunrise Medical warrants the Zippie Xpress frame against defects in materials and workmanship for the lifetime of the product. Lifetime is defined as 5 years.

**B. FOR ONE (1) YEAR**

We warrant all Sunrise-made parts and components of this device against defects in materials and workmanship for one year from the date of first consumer purchase.

**C. LIMITATIONS**

1. We do not warrant:
  - Tires, upholstery, and pads.
  - Damage from neglect, accident, misuse, or from improper installation or repair.
  - Products modified without Sunrise Medical's express written consent.
  - Damage from exceeding the weight limit.
2. This warranty is VOID if the original device serial number tag is removed or altered.
3. This warranty applies in the USA and Canada only. Check with your supplier to find out if international warranties apply.
4. This warranty is not transferable and only applies to the first consumer purchase of this device through an authorized Sunrise Medical dealer.

**D. WHAT WE WILL DO**

Our sole liability is to repair or replace covered parts. This is the exclusive remedy for consequential damages.

**E. WHAT YOU MUST DO**

1. Obtain from an authorized supplier while this warranty is in effect, prior approval for return or repair of covered parts.
2. Return the device or part(s), freight pre-paid, to Sunrise Mobility Products Division at: 2842 Business Park Avenue, Fresno, CA 93727-1328.
3. Pay the cost of labor to repair, remove or install parts.

**F. NOTICE TO CONSUMER**

1. If allowed by law, this warranty is in place of any other warranty (written or oral, express or implied, including a warranty of merchantability, or fitness for a particular purpose).
2. This warranty gives you certain legal rights. You may also have other rights that vary from state to state.

**G. ADDITIONAL WARRANTY INFORMATION**

For goods provided by Sunrise Medical Pty Ltd in Australia, our goods come with a guarantee by Sunrise that cannot be excluded under the Australian Consumer Law. You are entitled to a replacement or refund for a major failure and for compensation for any other reasonably foreseeable loss or damage. You are also entitled to have the goods repaired or replaced if the goods fail to be of acceptable quality and the failure does not amount to a major failure. The benefits to you given by this warranty are in addition to your other rights and remedies under a law in relation to the goods to which the warranty relates.

Record your serial number here for future reference:

---

Sunrise Medical • 2842 Business Park Ave. • Fresno, CA 93727 • USA  
In Canada (800) 263-3390



Customer Service: 800.333.4000  
[www.SunriseMedical.com](http://www.SunriseMedical.com)

©2016 Sunrise Medical (US) LLC  
12.16 9921700000 Rev. E